

FRMADE IN ITALY



COLLECTIONS

 **Francolight**[®]
DESIGNING THE ITALIAN WAY

The background of the image is a dark teal color with a repeating pattern of concentric circles in a lighter shade of teal. The circles are arranged in a grid, with each circle centered on a grid intersection. The text is centered horizontally and vertically.

10⁰ ANNIVERSARY

R S A R I O  **Francolight**[®]
DESIGNING THE ITALIAN WAY

Mi accorgo di una buona **IDEA** quando si accende la **LUCE** della mia **PASSIONE.**

Michele Loria

Collection one

Zip

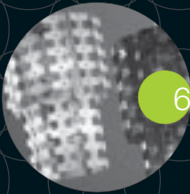

6

Riflessi



88

Crystal



138

Jo



18

Ocean



92

Link

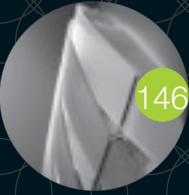

146

Simple



34

Land



98

Ricamo



152

Bells



40

Aly



104

Venere



158

Linear



46

Iris

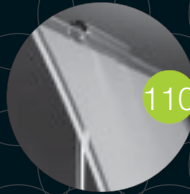

110

Goccia



162

Black&white



54

Maya



116

Doremi...



168

Arlek & Round



62

Tribal



118

Aria



172

You&me

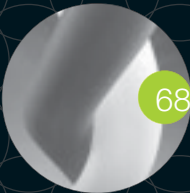

68

Sound



124

Variant



178

Petit
Buochon



74

Chi



130

Flexo



182

Dado



76

Circle



136

Collection two

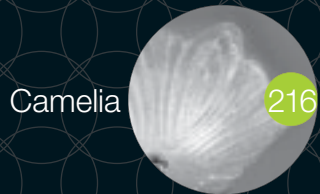
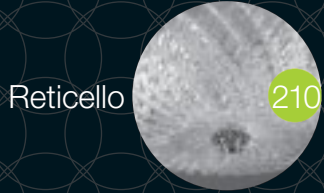

Living Division





 **Francolight**[®]
DESIGNING THE ITALIAN WAY



Collection one

Struttura cromo, elementi policarbonato anti striscio e antistatico, per le colorazioni rosso fumè e bianco, oppure metallo cromato o dorato.

Chrome fixture, anti-scratch and anti-static polycarbonate components for smoke-grey, red and white coloured lamps or available with a chrome plated or gold finish metal.

Monture en Métal chromé, détails en polycarbonate antirampe et antistatique, finition rouge, fumé et blanc ou métal chromé et doré.

Chromaufbau, Elemente aus kratzfestem und antistatischem Polycarbonat in den Färbungen rot, rauchfarben und weiß, oder verchromtes oder vergoldetes Metall.

Estructura cromada, elementos de policarbonato antiroce y antiestático, para los colores rojo fumé y blanco, o metal cromado o dorado.

Хромированная конструкция, элементы из нецарапающегося антистатического поликарбоната, для цветовой тональности дымчатого красного и белого цвета или же металлического хромированного или позолоченного.



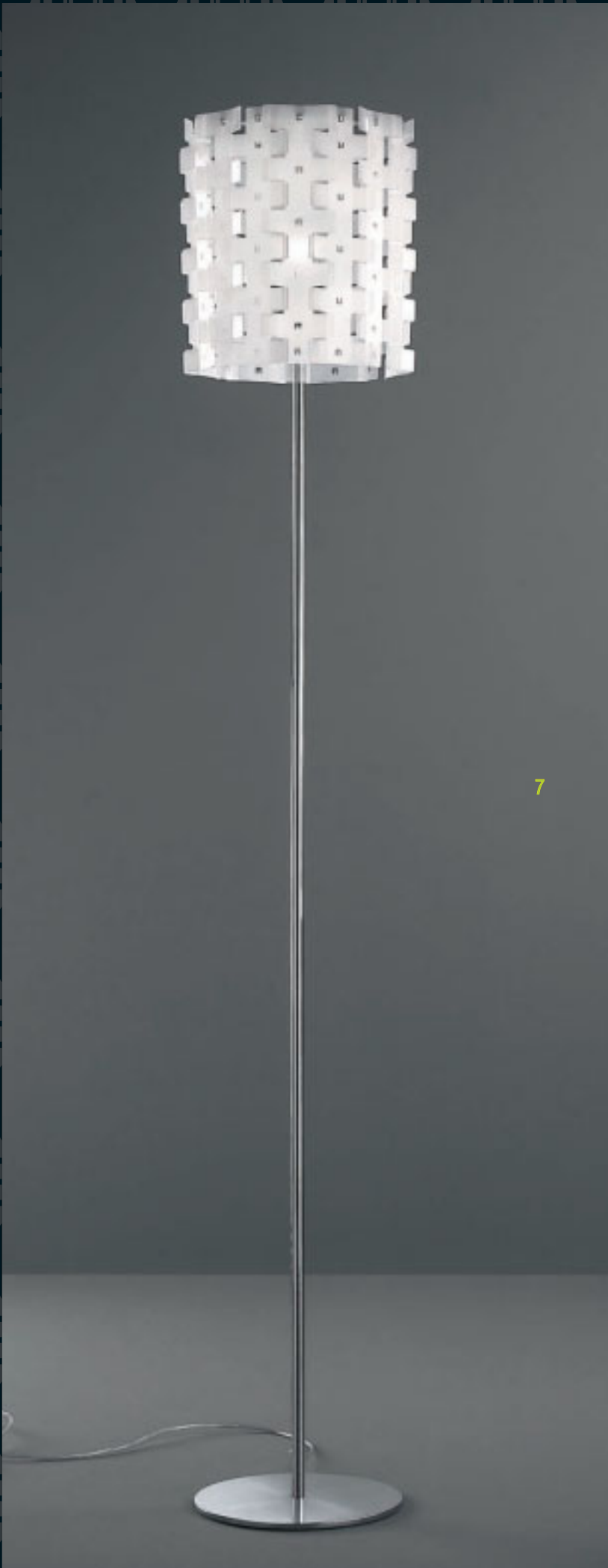

7



180 cm
70.86"

Floor lamp
ZIP Pl...

Max 1x150W E27 halogen

13 20 33 08 09 11



CE IP20

30 cm
11.81"



Pendant lamp

ZIP SO4...

Max 7x100W E27 

Max 7x23W E27  

■ 13 ■ 20 ■ 33 ■ 08 ■ 09 ■ 11

CE IP20  

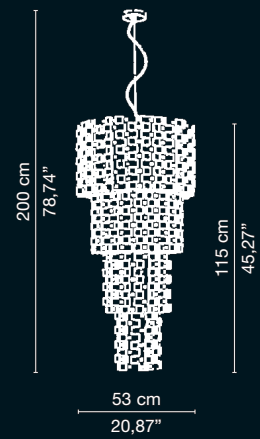

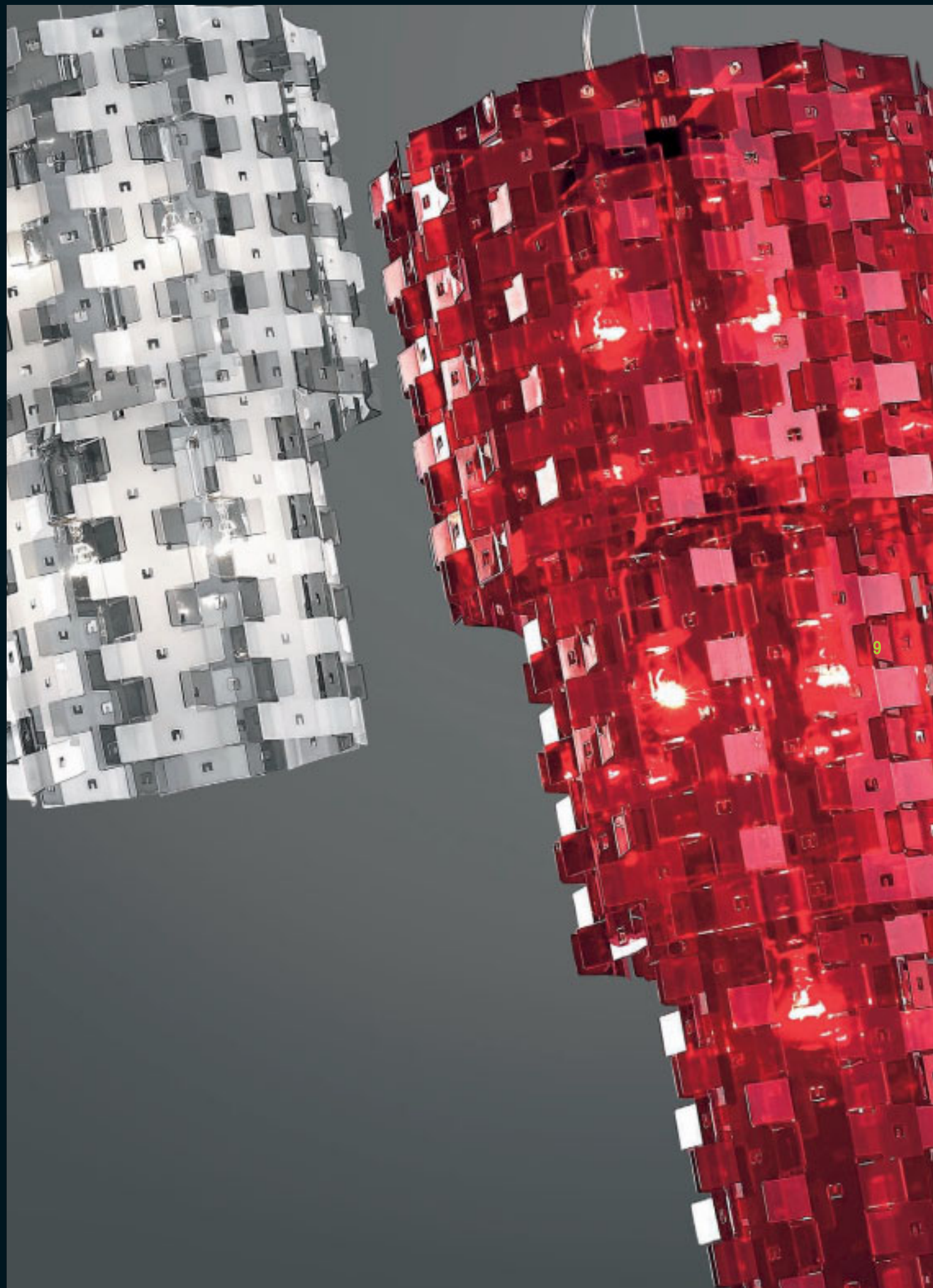







Pendant lamp

ZIP SO3...

Max 5x100W E27 

Max 5x23W E27  

■ 13 ■ 20 ■ 33 ■ 08 ■ 09 ■ 11

CE IP20  

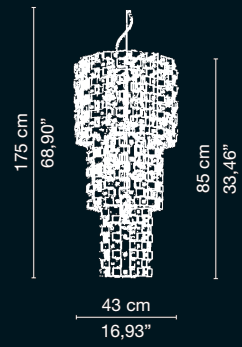

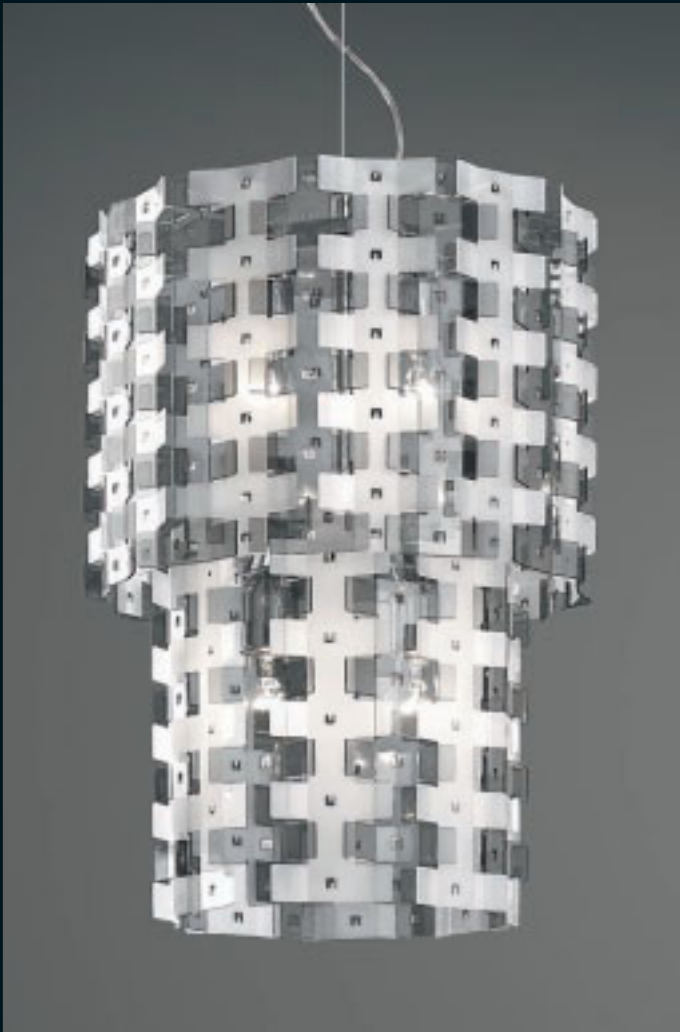

Pendant lamp

ZIP SO2...

Max 4x100W E27

Max 4x23W E27

■ 13 ■ 20 ■ 33 ■ 08 ■ 09 ■ 11

CE IP20

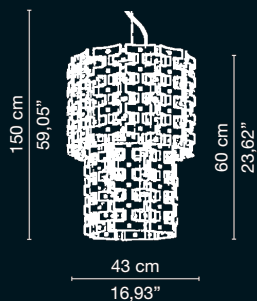

Pendant lamp

ZIP SOP...

Max 1x100W E27

Max 1x23W E27

■ 13 ■ 20 ■ 33 ■ 08 ■ 09 ■ 11

CE IP20

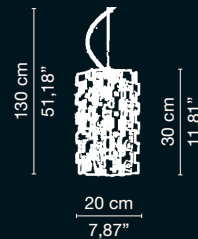









Pendant lamp

ZIP SOM...

Max 1x150W E27 

Max 1x23W E27  

■ 13 ■ 20 ■ 33 ■ 08 ■ 09 ■ 11



CE IP20  





Pendant lamp

ZIP SOG...

Max 1x150W E27 

Max 1x23W E27  

■ 13 ■ 20 ■ 33 ■ 08 ■ 09 ■ 11

CE IP20  

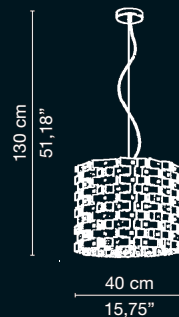







Ceiling lamp

ZIP PL2...

Max 1x100W E27 

Max 1x23W E27  

■ 13 ■ 20 ■ 33 ■ 08 ■ 09 ■ 11

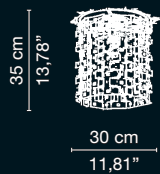

CE IP20  





Ceiling lamp

ZIP PL1...

Max 1x100W E27 

Max 1x23W E27  

■ 13 ■ 20 ■ 33 ■ 08 ■ 09 ■ 11

CE IP20  









Wall lamp

ZIP AP...

Max 1x100W E27 

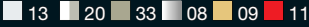
Max 1x23W E27  



CE IP20  

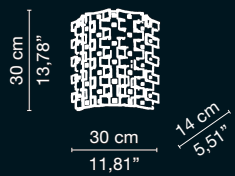

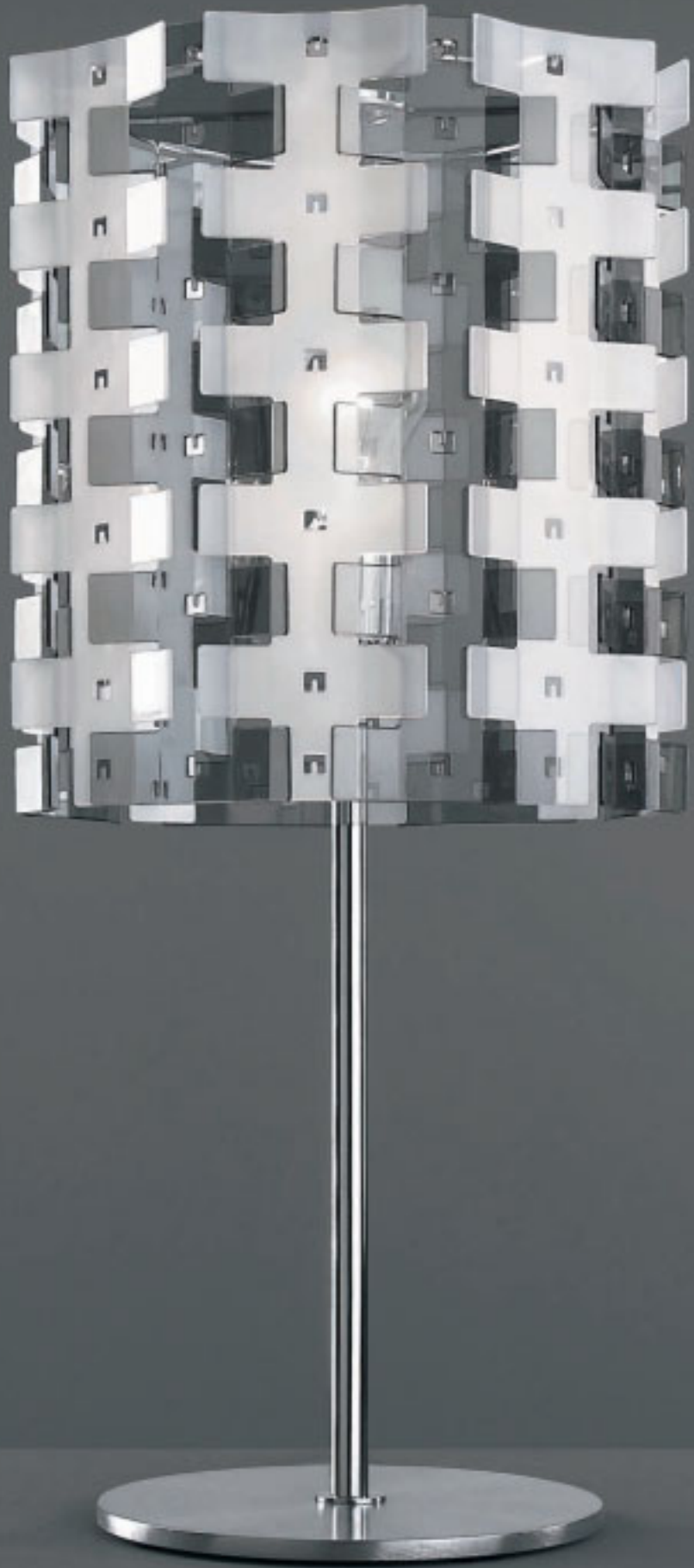









Table lamp

ZIP LT...

Max 1x150W E27  halogen

Max 1x23W E27  

■ 13 ■ 20 ■ 33 ■ 08 ■ 09 ■ 11

CE IP20  

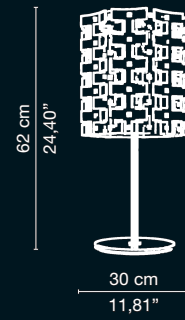







Table lamp

ZIP LU...

Max 1x100W E27  halogen

Max 1x23W E27  

■ 13 ■ 20 ■ 33 ■ 08 ■ 09 ■ 11

CE IP20  



Struttura in ottone cromato lucido,
vetri arancio, bianco e specchio.

Brass fixture with a polished
chrome plated finish, orange,
white or mirror effect diffusers.

18

Monture en laiton chromé brillant,
verres orange, blanc et finition miroir.

Aufbau aus glänzend
verchromtem Messing, Gläser
orange, weiß oder verspiegelt.

Estructura de latón cromado brillante,
vidrio anaranjado, blanco y espejo.

Конструкция из блестящей
хромированной латуни, стекла
оранжевые, белые и зеркальные.



Floor lamp

JO PI...

Max 1x150W E27 halogen

01 26 27

CE IP20





20





Pendant lamp

JO SO6...

Max 6x40W G9 

■ 01 ■ 26 ■ 27

CE IP20  

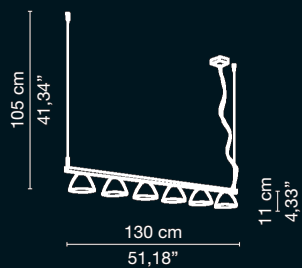



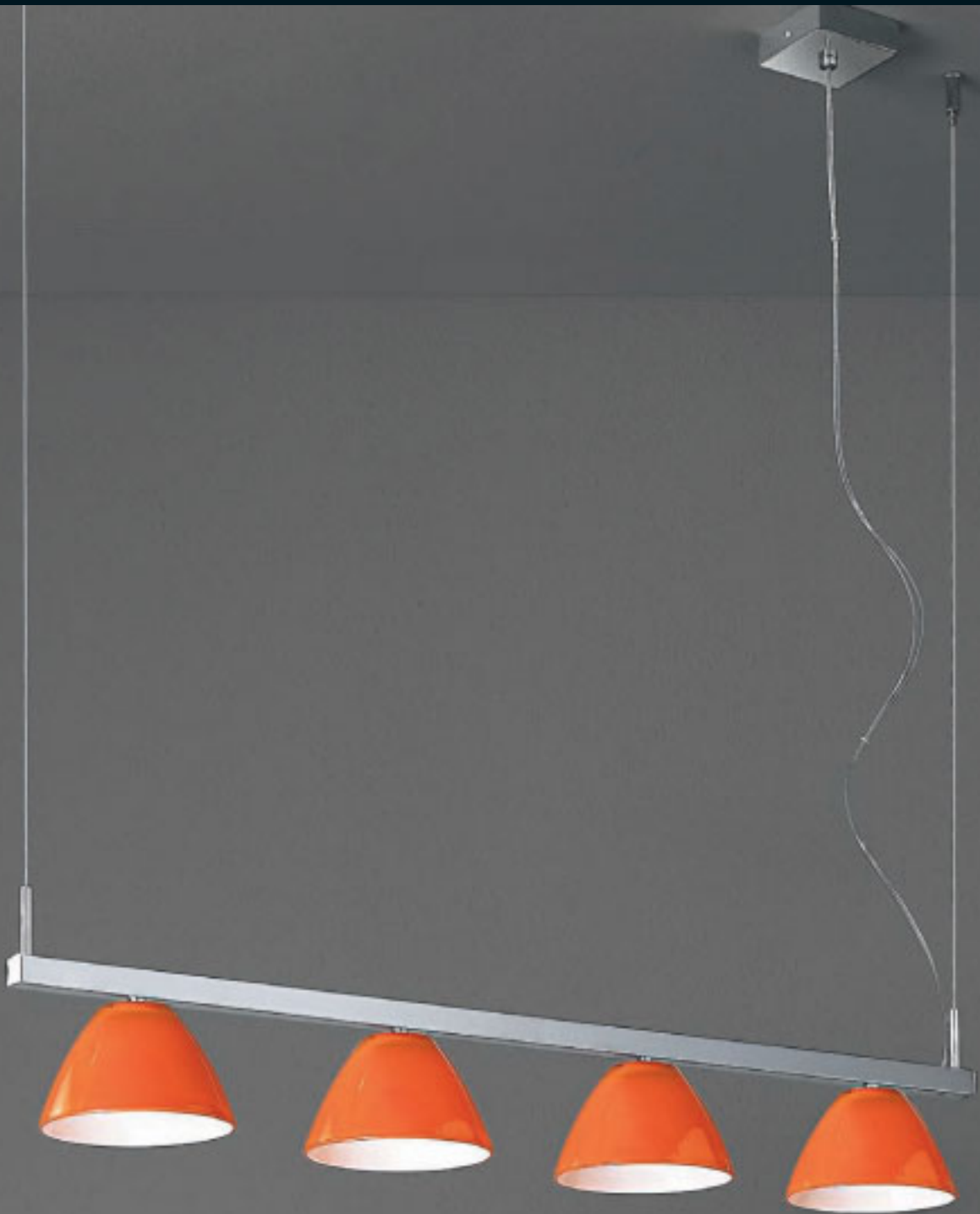

**Pendant lamp**

JO SO4...

Max 4x40W G9 

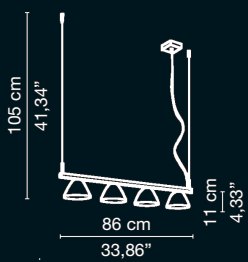
■ 01 ■ 26 ■ 27

CE IP20  





Pendant lamp

JO SO2...

Max 2x40W G9 

■ 01 ■ 26 ■ 27

CE IP20  

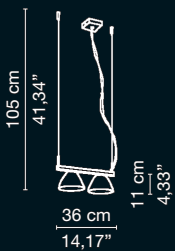





Pendant lamp

JO SO4 B...

Max 8x40W G9

01 26 27

IP20

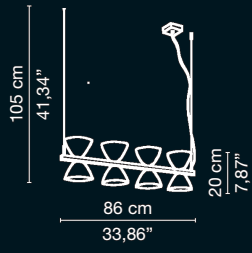

25

Pendant lamp

JO SO2 B...

Max 4x40W G9

01 26 27

IP20

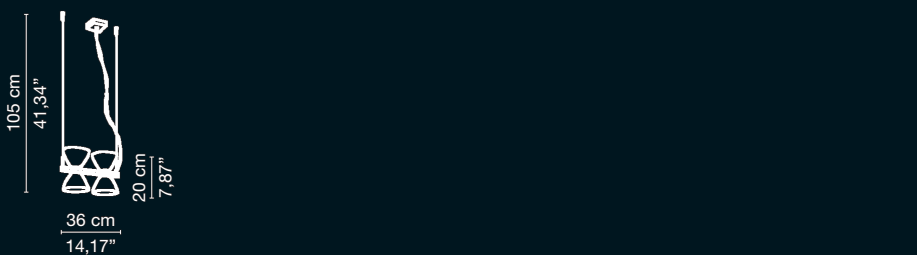
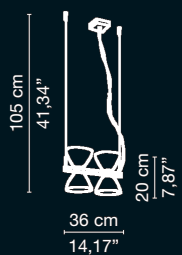

Pendant lamp

JO SO1 B...

Max 2x40W G9

01 26 27

IP20

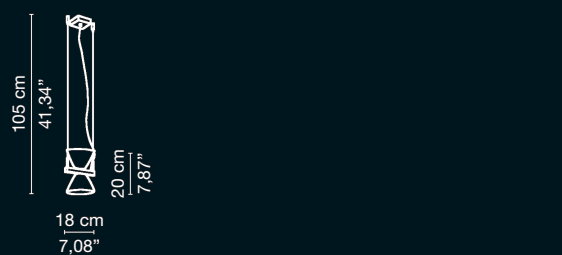
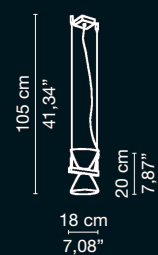



**Pendant lamp**

JO SO6 B...

Max 12x40W G9 

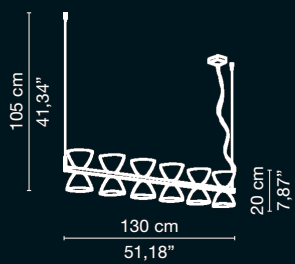
■ 01 ■ 26 ■ 27

CE IP20  







Pendant lamp

JO SOP...

Max 1x40W G9 

■ 01 ■ 26 ■ 27

CE IP20  

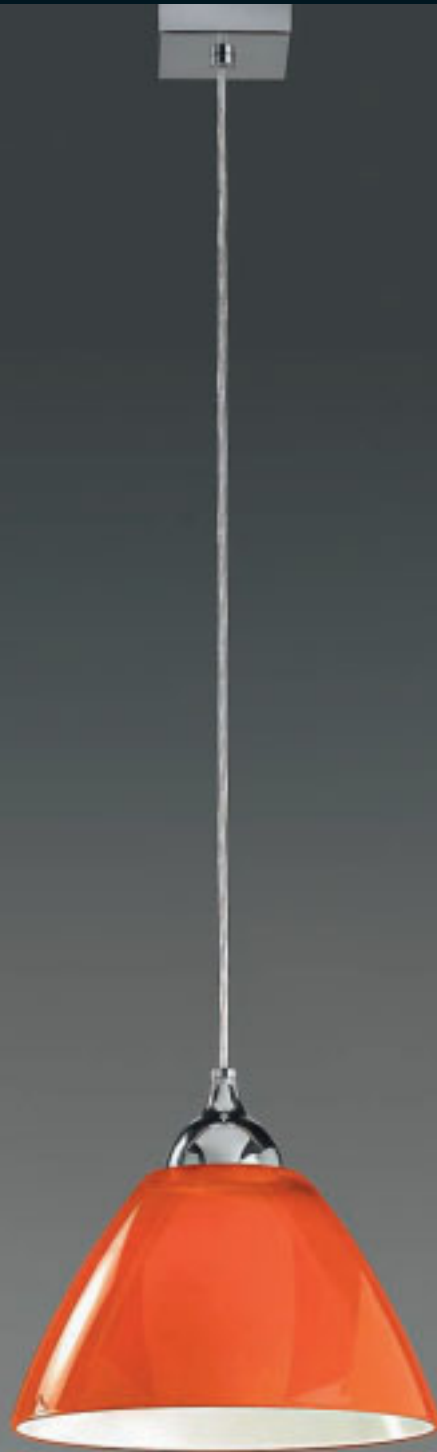
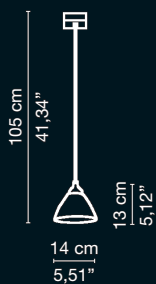



Pendant lamp

JO SOG...

Max 1x100W E27 

■ 01 ■ 26 ■ 27

CE IP20  



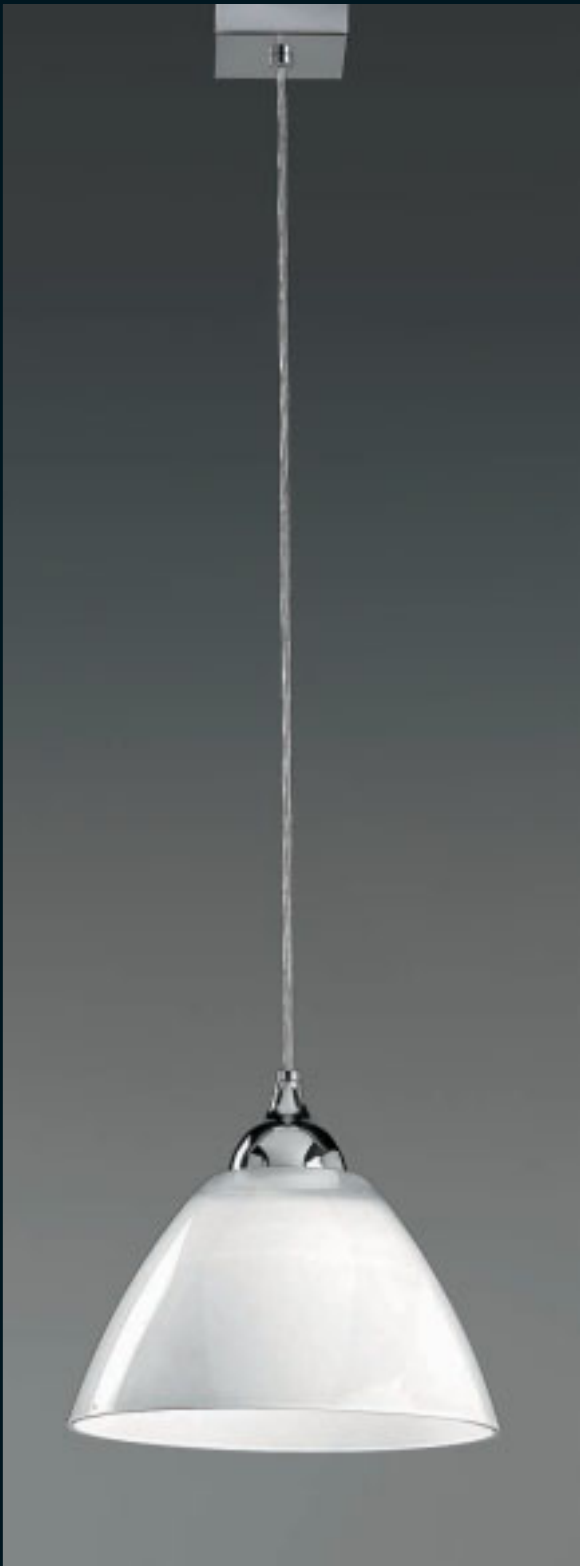

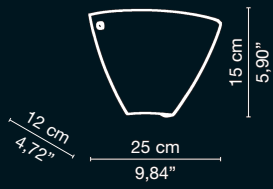



JO AP...

Max 1x100W R7s 

■ 01 ■ 26 ■ 27

CE IP20  





Wall lamp

JO AP2...

Max 2x40W G9

■ 01 ■ 26 ■ 27

CE IP20



Wall lamp

JO AP1...

Max 1x40W G9

■ 01 ■ 26 ■ 27

CE IP20





Table lamp

JO LT...

Max 1x100W E27

■ 01 ■ 26 ■ 27

CE IP20



Table lamp

JO LU...

Max 1x60W E14

■ 01 ■ 26 ■ 27

CE IP20

Simple

Struttura acciaio inox,
diffusore in tubo pirex ribruciato.

Stainless steel fixture, fire-finished
pirex tube shaped diffuser.

Monture acier inox,
diffuseur en tube pyrex ri-brûlé.

Edelstahlaufbau, Diffusor aus
feuerpoliertem Pyrexrohr.

Estructura de acero inoxidable,
difusor con tubo pyrex quemado.

Конструкция из нержавеющей
стали, отражатель в трубке из
обожженного пирекса.





Pendant lamp

SIMPLE SO1

Max 2x39W G5

CE IP20  

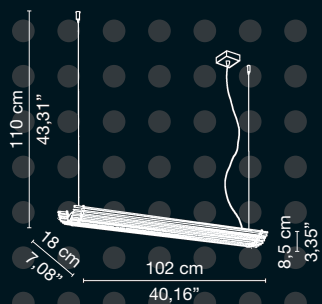

Pendant lamp

SIMPLE SO2

Max 2x24W G5

CE IP20  

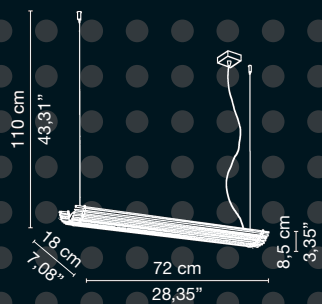

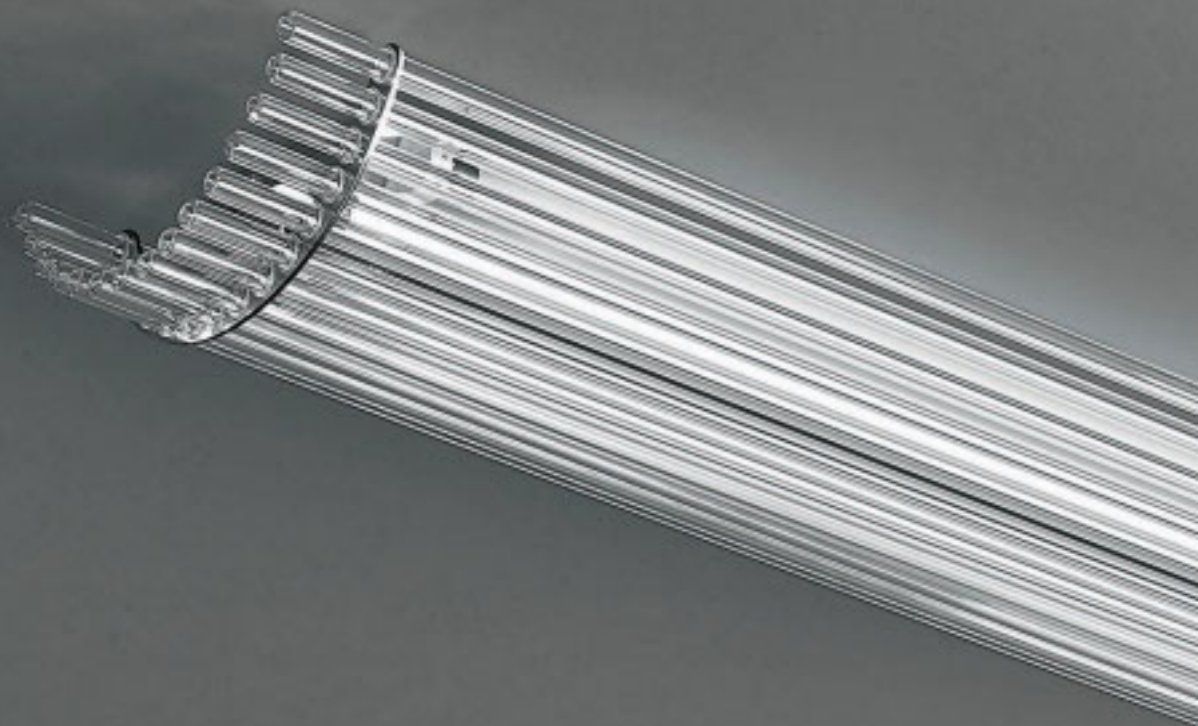

36

Ceiling lamp

SIMPLE PL1

Max 2x39W G5 ←

CE IP20  

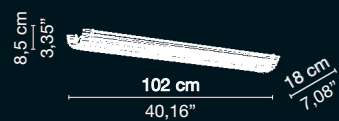

Ceiling lamp

SIMPLE PL2

Max 2x24W G5 ←

CE IP20  

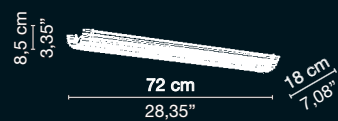



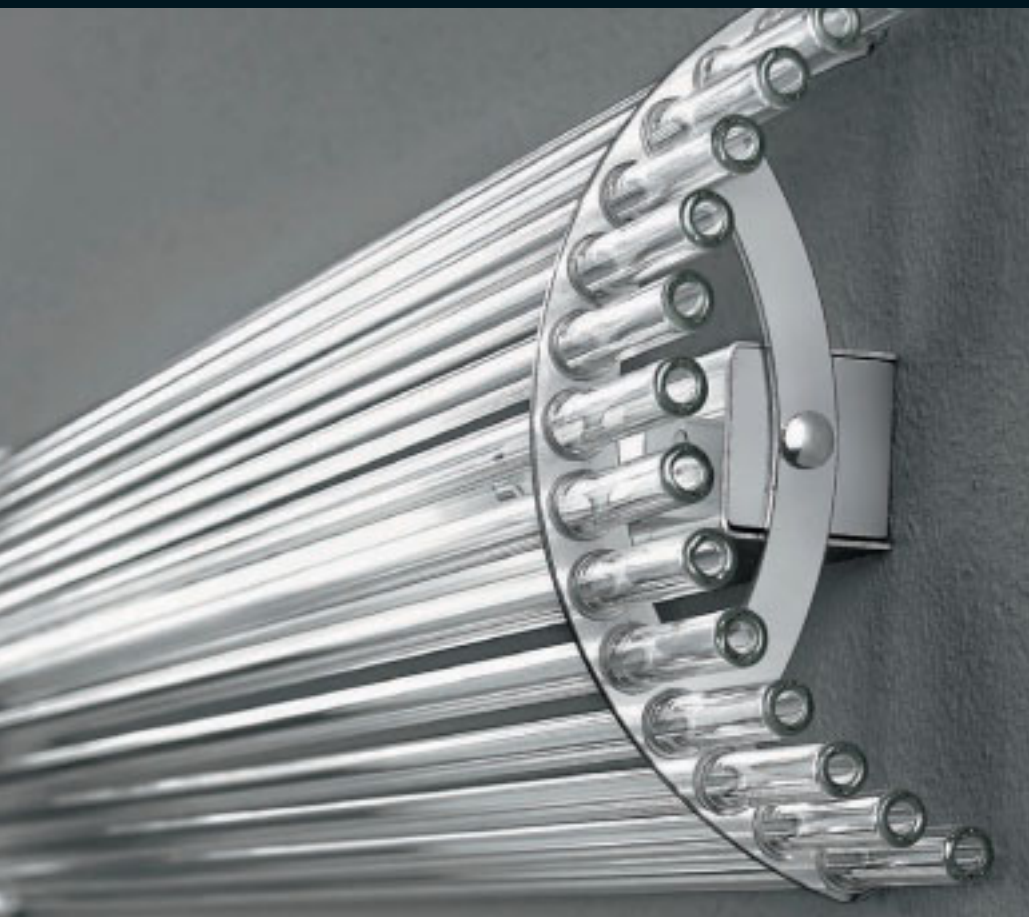

38



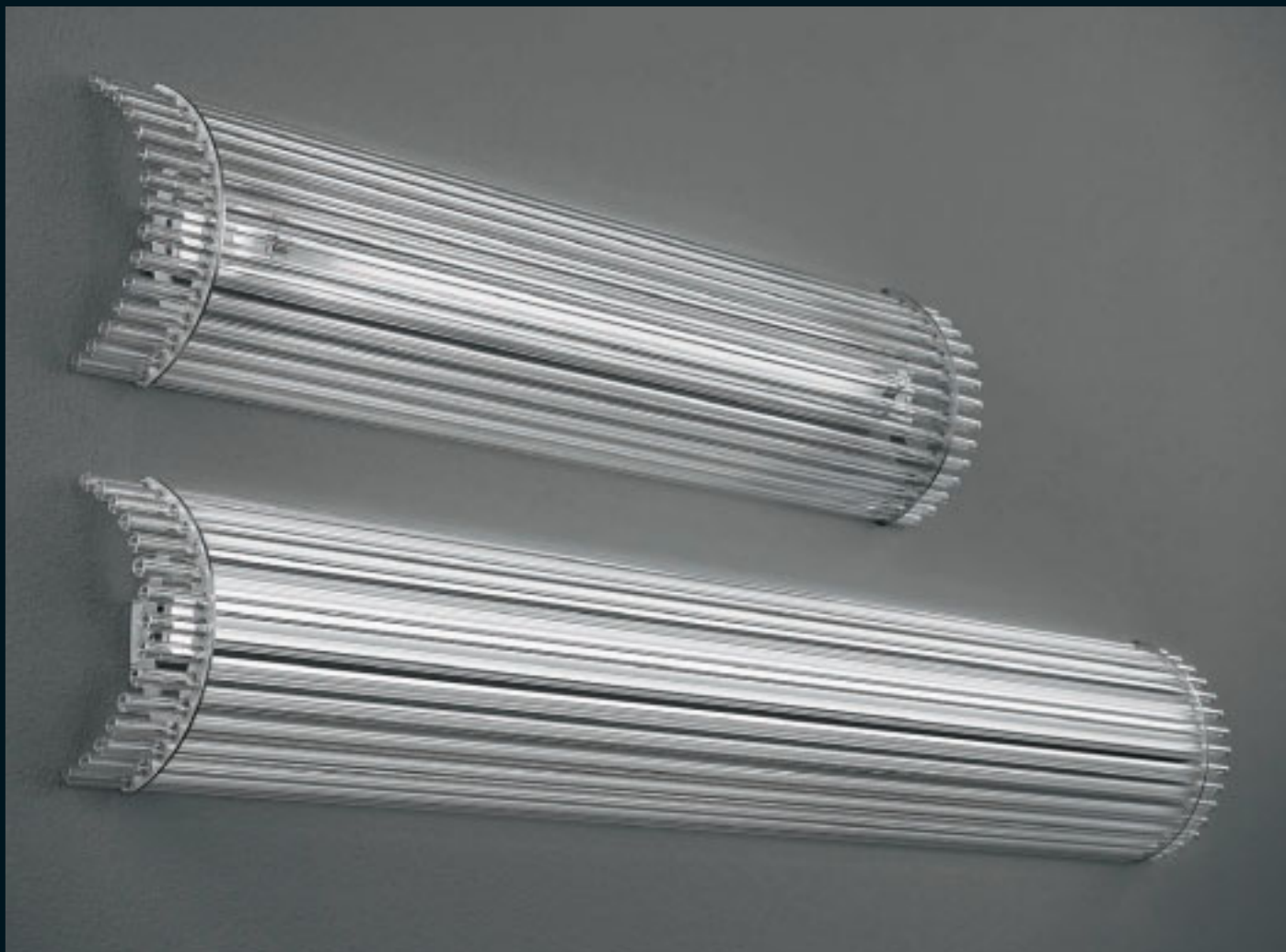

Wall lamp

SIMPLE AP...

Max 1x54W G5 ←

CE IP20

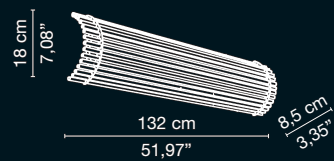

Wall lamp

SIMPLE AP1...

Max 1x39W G5 ←

CE IP20

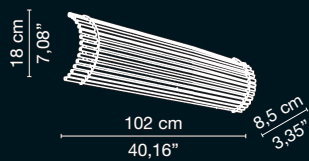

Wall lamp

SIMPLE AP2...

Max 1x24W G5 ←

CE IP20

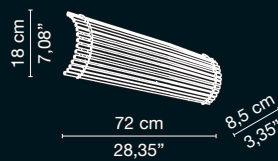

Bells

Struttura in metallo cromato lucido,
vetro pirex aperto a mano.

Chrome plated metal fixture
with a polished finish,
hand moulded pirex diffuser.

Monture en métal chromé brillant,
verre pyrex ouvert à la main.

Aufbau aus glänzend verchromtem
Metall, handgeöffnetes Pyrexglas.

Estructura de metal cromado brillante,
vidrio pyrex abierto a mano.

Конструкция из блестящего
хромированного металла, стекло
пирекс раскрыто вручную.



40



180 cm
70.87"

27 cm
10.63"

Floor lamp
BELLS PI
Max 1x100W E27



CE IP20



Pendant lamp

BELLS SOP

Max 1x100W E27 

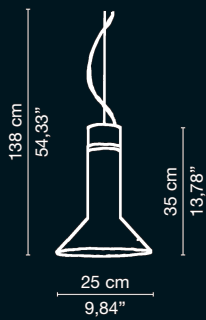

CE IP20  



Pendant lamp

BELLS SOG

Max 1x100W E27 

CE IP20  

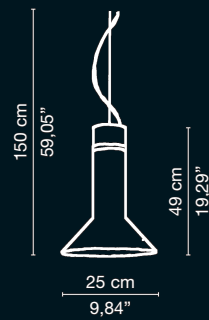



Ceiling lamp
BELLs PL3
 Max 1x100W E27



Ceiling lamp
BELLs PL2
 Max 1x100W E27

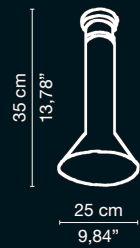

Ceiling lamp
BELLs PL1
 Max 1x100W E27



CE IP20

CE IP20

CE IP20

∞





44

Table lamp

BELLS LU

Max 1x100W E27 

CE IP20  

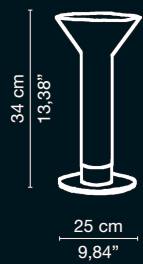



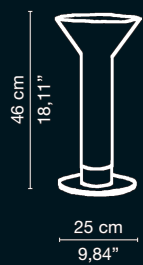

Table lamp

BELLS LT

Max 1x100W E27 

CE IP20  



Struttura in acciaio inox,
vetro extra chiaro con finitura serigrafia.

Stainless steel fixture, extra-clear glass
diffuser with silk-screen printed finish.

Monture en acier inox,
verre extra clair avec finition serigraphé.

Edelstahlaufbau, extra helles Glas
mit Siebdruckfinish.

Estructura de acero inoxidable, vidrio
extraclaro con acabado serigrafiado.

Конструкция из нержавеющей
стали, выствленное стекло с
сеткографической отделкой.





Pendant lamp

LINEAR SO1

Max 2x39W G5

CE IP20 ES

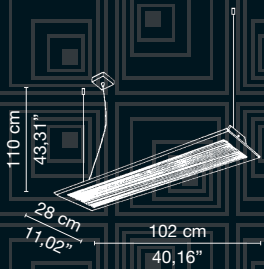

Pendant lamp

LINEAR SO2

Max 2x24W G5

CE IP20 ES

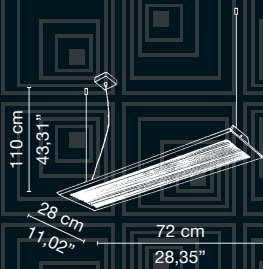

Ceiling lamp

LINEAR PL4

Max 2x39W G5 

CE IP20   

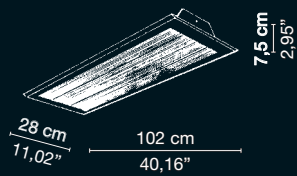

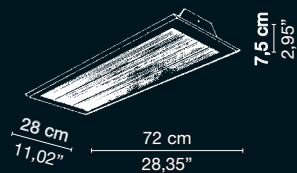

Ceiling lamp

LINEAR PL

Max 2x24W G5

CE IP20







Ceiling / Wall lamp

LINEAR PL2

Max 1x18W TCL 

CE IP20  

8,1 cm
3,19"

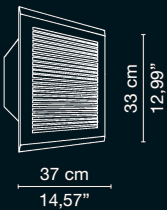

Ceiling / Wall lamp

LINEAR PL3

Max 1x24W TCL 

CE IP20  

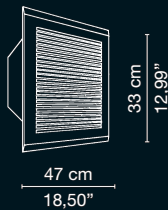

8,1 cm
3,19"



Ceiling / Wall lamp

LINEAR PL1

Max 1x36W TCL 

CE IP20  

8,1 cm
3,19"

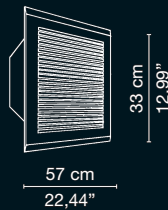



52



Wall lamp
LINEAR AP
Max 1x54W G5
CE IP20

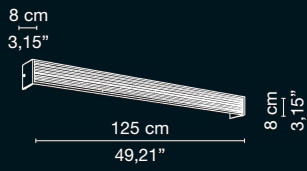

Wall lamp
LINEAR AP1
Max 1x39W G5
CE IP20

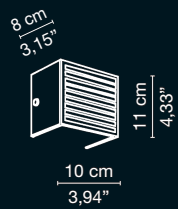
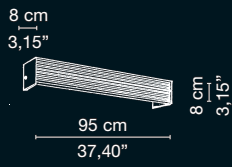

Wall lamp
LINEAR AP2
Max 1x40W G9
CE IP20

Wall lamp
LINEAR AP3
Max 1x24W G5
CE IP20

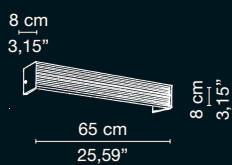

Black&white

Vetro extra-chiaro combinato
con vetro nero diffusore.

54

Ultra-clear glass matched
with black glass diffuser.

Verre très clair associé
à du verre noir diffuseur.

Extraklares Glas kombiniert mit
lichtstreuendem schwarzen Glas.

Vidrio extraclaro combinado
con vidrio negro difusor.

Высветленное стекло в комбинации с
черным стеклянным отражателем.





Pendant lamp

WHITE SOG ■

BLACK SOG □

Max 2x39W G5 ←

CE IP20  

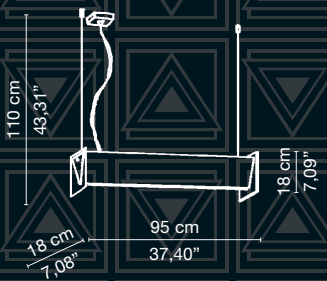





Pendant lamp

WHITE SOP ■

BLACK SOP ■

Max 2x24W G5 ←

CE IP20  

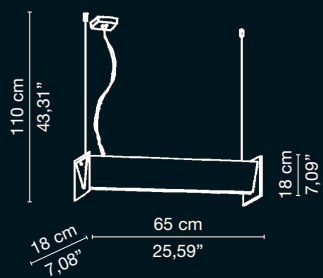







Pendant lamp

WHITE SO ■

BLACK SO ■

Max 1x250W E27 

Max 1x23W E27  

CE IP20  

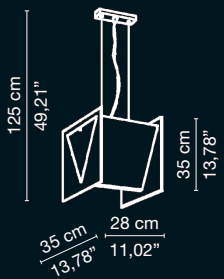





Pendant lamp

WHITE SO2 ■

BLACK SO2 ■

Max 2x60W G9

CE IP20

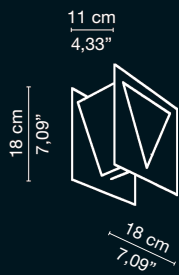
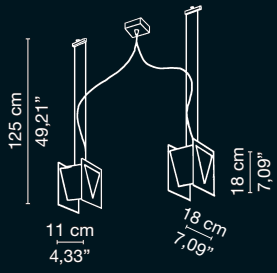

Ceiling lamp

WHITE PL ■

BLACK PL ■

Max 1x60W G9

CE IP20





Wall lamp

WHITE AP1 ■

BLACK AP1 ■

Max 4x60W G9

CE IP20

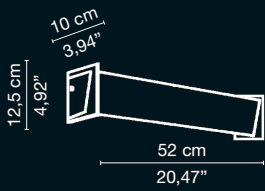

Wall lamp

WHITE AP1A ■

BLACK AP1A ■

Max 1x36W 2G11

CE IP20

Wall lamp

WHITE AP3 ■

BLACK AP3 ■

Max 2x60W G9

CE IP20

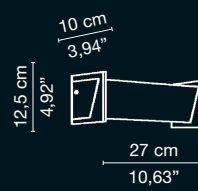

Wall lamp

WHITE AP3A ■

BLACK AP3A ■

Max 1x18W G24d-2

CE IP20

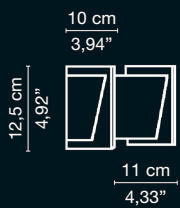

Wall lamp

WHITE AP2 ■

BLACK AP2 ■

Max 1x60W G9

CE IP20

Desk lamp

WHITE LUA ■

BLACK LUA ■

Max 1x75W G9

CE IP20

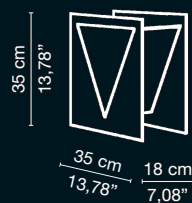

Desk lamp

WHITE LUB ■

BLACK LUB ■

Max 1x60W G9

CE IP20

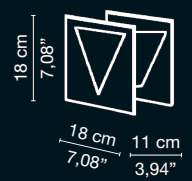

Arlek & Round

Metacrilato colato, nei colori neutro,
arancio, giallo, azzurro, viola.

Cast methacrylate available in neutral,
orange, yellow, sky blue and purple.

62

Méthacrylate moulé dans les coloris
neutre, orange, jaune, bleu et violet.

Geschmolzenes Metacrylat
in den Farben Neutral, Orange,
Gelb, Hellblau, Violett.

Metacrilato de colada, de color neutro,
anaranjado, amarillo, azul, violeta.

Отлитый метакрилат в цветовой
гамме: нейтральный, оранжевый,
желтый, голубой, фиолетовый.



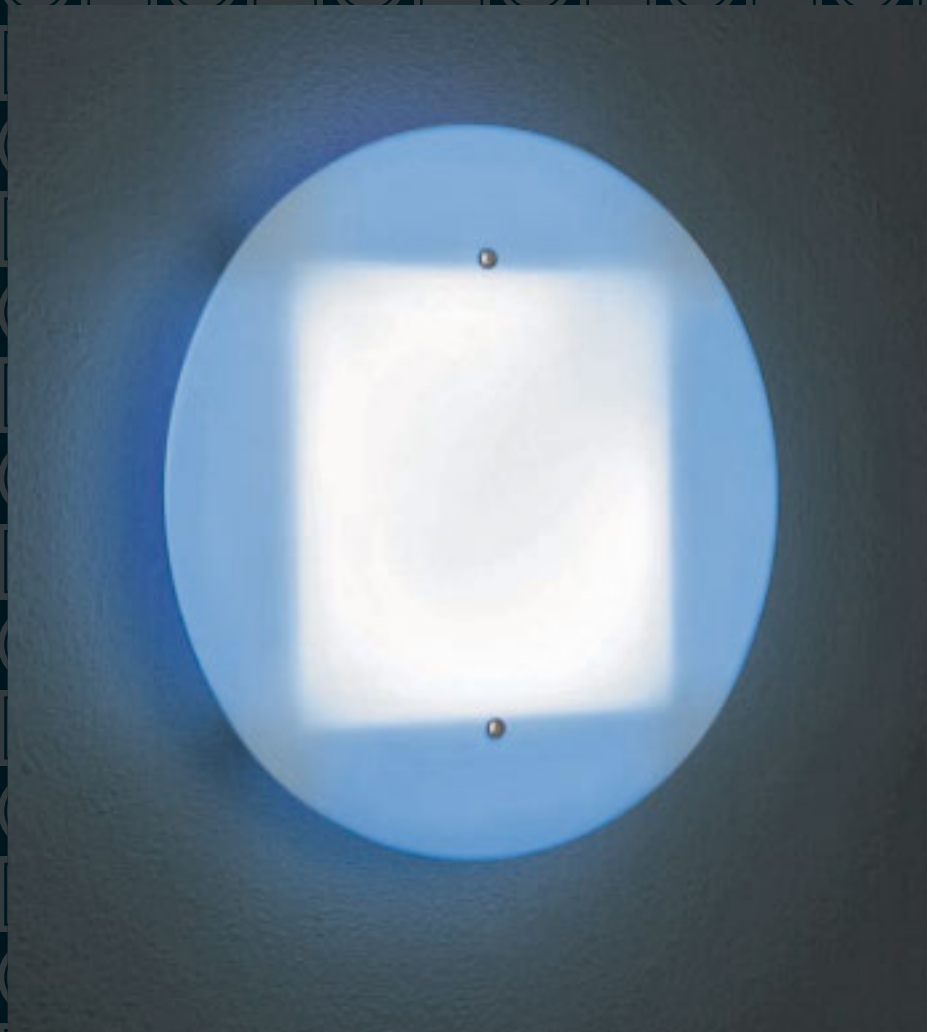

Wall lamp

ARLEK AP 06

Max 1x22W 2Gx13



Wall lamp

ARLEK AP 26

Max 1x22W 2Gx13



64







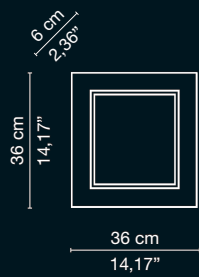

Wall lamp

ARLEK AP 01

Max 1x22W 2Gx13







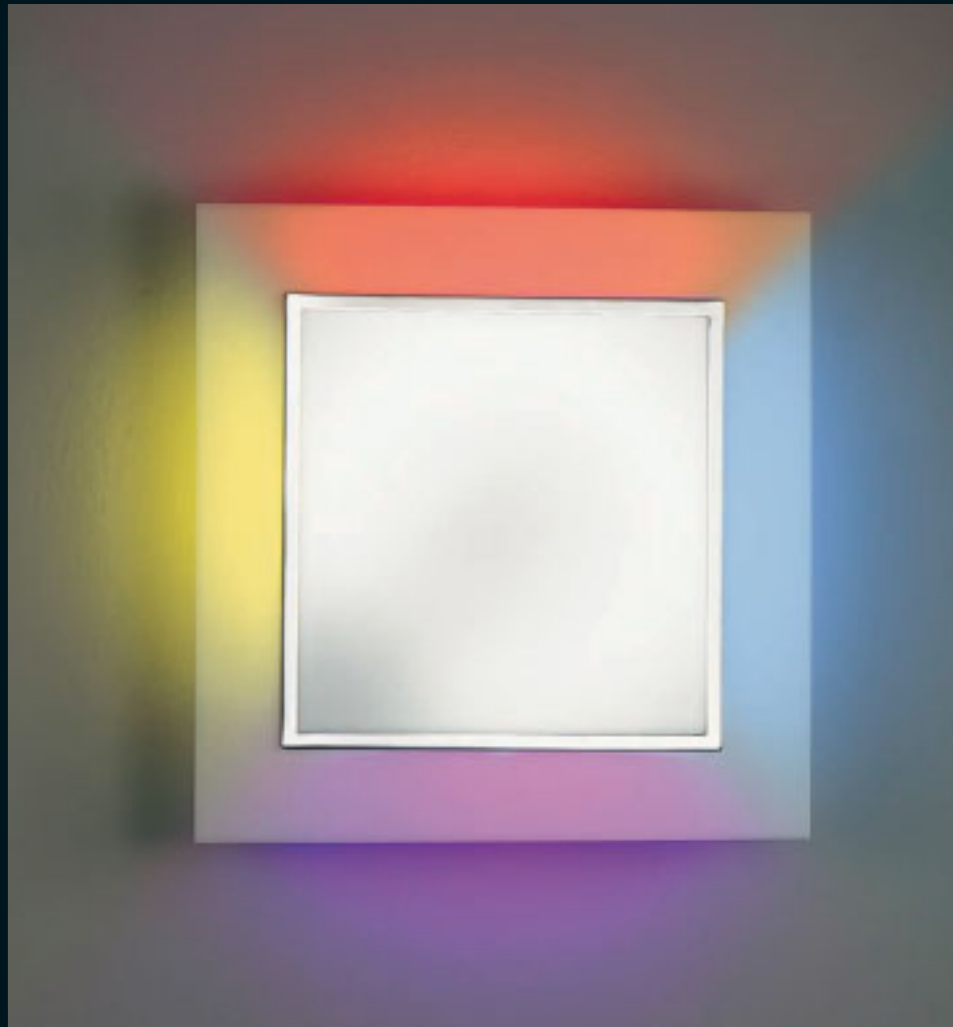

Wall lamp
ARLEK AP 20
Max 1x22W 2Gx13 
 IP20   







65







Wall lamp
ARLEK AP 29
Max 1x22W 2Gx13 
 IP20   







Wall lamp
ARLEK AP 30
Max 1x22W 2Gx13 
 IP20   







Wall lamp
ROUND AP 06
Max 1x22W 2Gx13 
 IP20   



Wall lamp
ROUND AP 26
Max 1x22W 2Gx13 
 IP20   







66

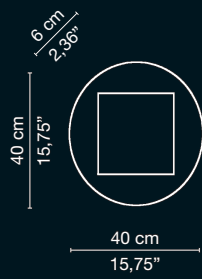



Wall lamp
ROUND AP 01
Max 1x22W 2Gx13 
 IP20   



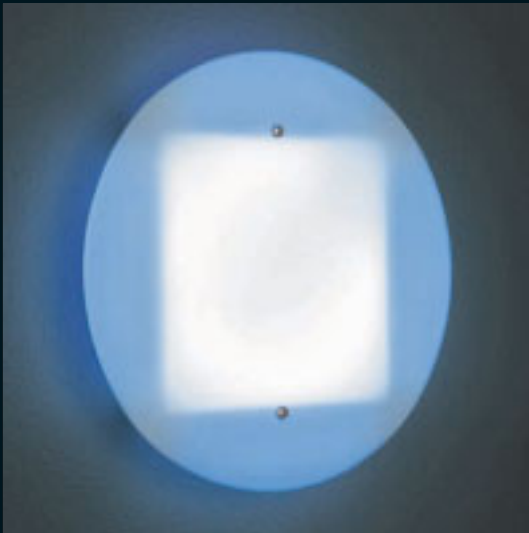
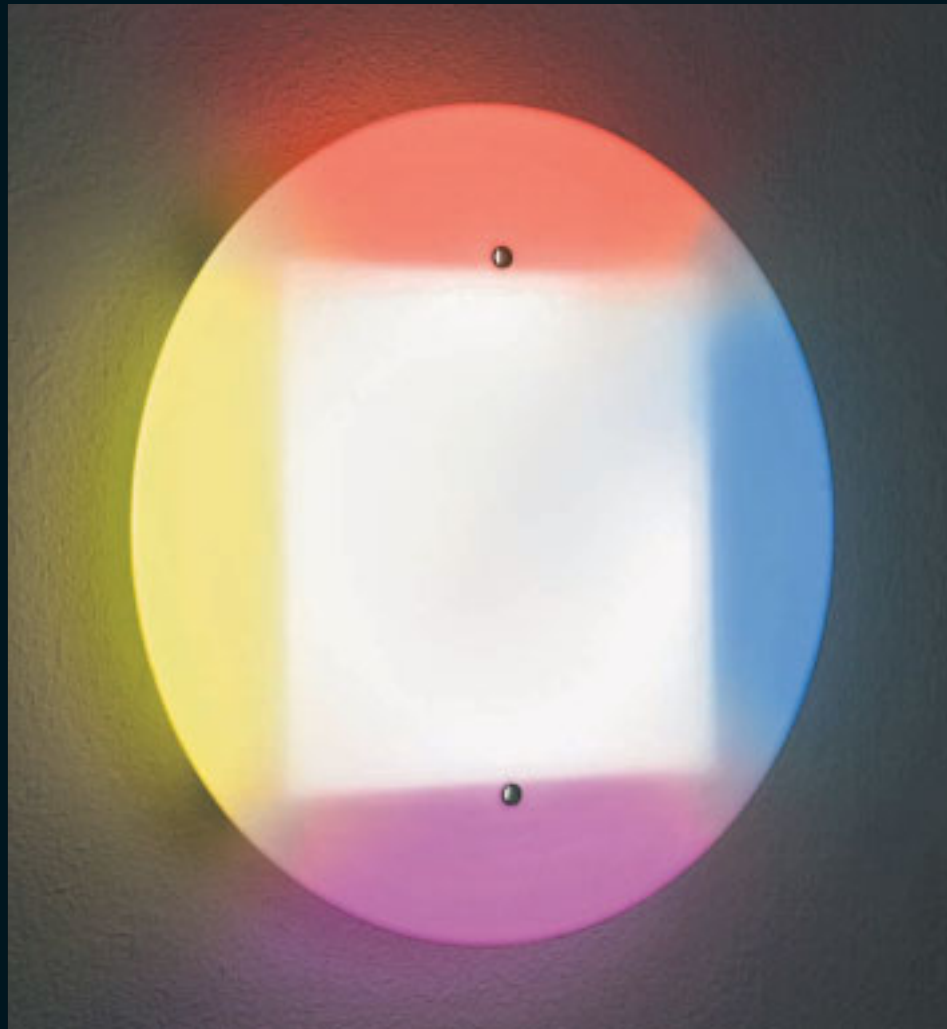





Wall lamp
 ROUND AP 20
 Max 1x22W 2Gx13 
 IP20  

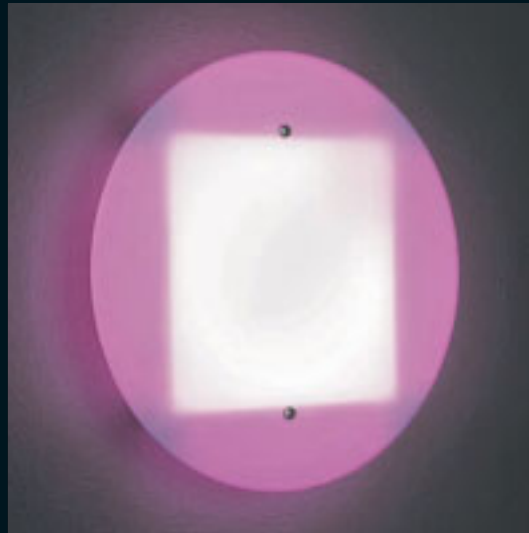

Wall lamp
 ROUND AP 29
 Max 1x22W 2Gx13 
 IP20  



Wall lamp
 ROUND AP 30
 Max 1x22W 2Gx13 
 IP20  



You&me

Realizzata in polietilene atossico,
riciclabile al 100% e stabilizzato UVA.

You&me è formata da due elementi
che possono essere divisi
in due punti luce differenti.

Made from non-toxic polyethylene,
100% recyclable and UVA stabilized.

You&Me formed of two elements
that can be divided in two different
lighting spots.

Réalisée en polyéthylène atoxique
100% recyclable et stabilisé UVA.

You&me est formée de deux éléments
pouvant être divisés en deux points de
lumière différents.

68

Hergestellt aus ungiftigem Polyäthylen,
100% wiederverwertbar
und UVA-stabilisiert.

You&Me besteht aus zwei Elementen,
die zu zwei unterschiedlichen
Lichtquellen werden können.

Realizada en polietileno atóxico, 100%
reciclable y estabilizado UVA.

You&me está formada por dos
elementos que se pueden dividir en dos
puntos de luz diferentes.

Изготовлен из нетоксичного
полиэтилена, перерабатывающегося
на 100% и стабилизированного на
ультрафиолетовое излучение.

You&me состоит из двух элементов,
которые могут быть разделены на две
отдельные лампы.

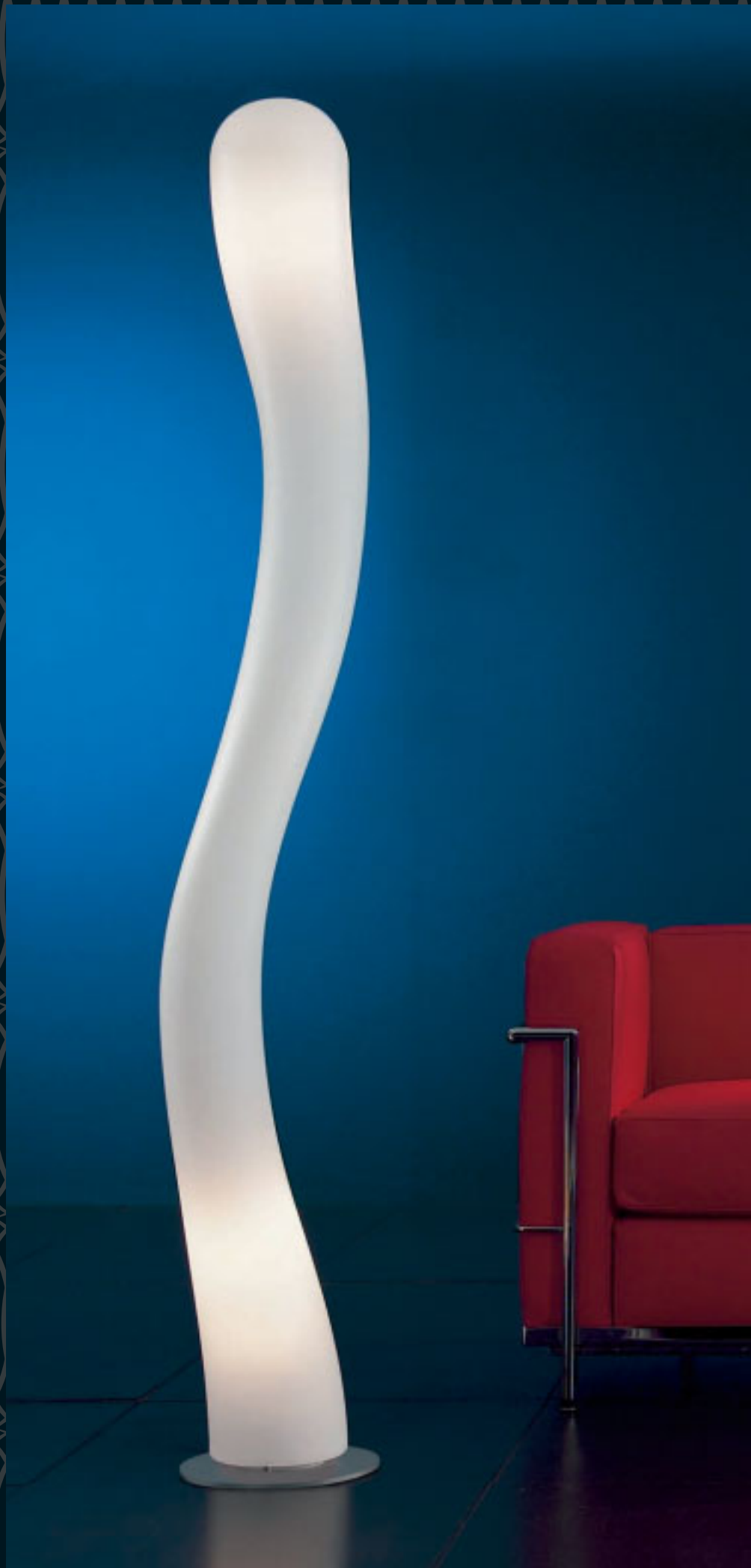





Floor lamp
YOU 01
Max 2x100W E27 
+ 1x60W E14 
CE IP20 

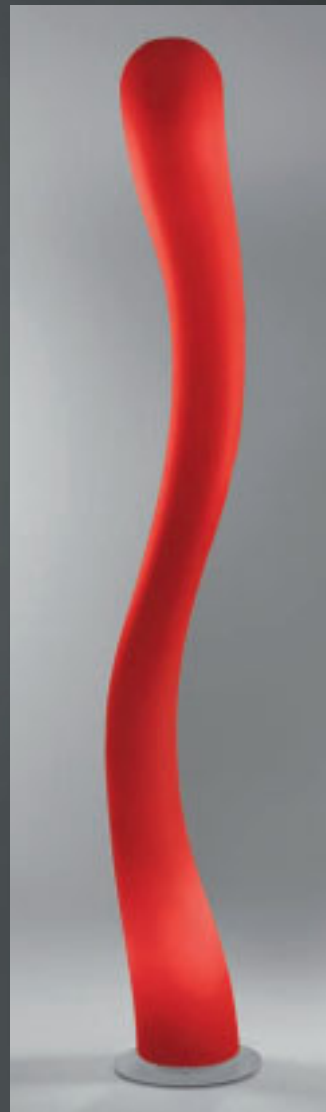

Floor lamp
YOU 11
Max 2x100W E27 
+ 1x60W E14 
CE IP20 

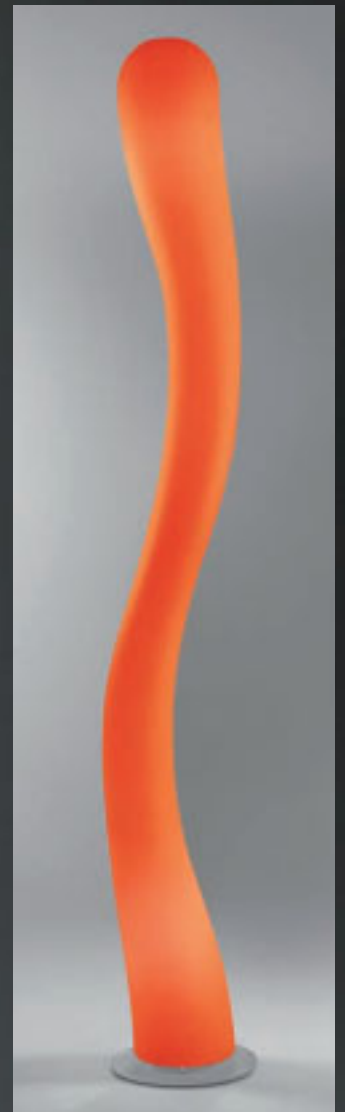

Floor lamp
YOU 26
Max 2x100W E27 
+ 1x60W E14 
CE IP20 



Floor lamp
YOU 06
Max 2x100W E27
+ 1x60W E14
CE IP20



Floor lamp
YOU 29
Max 2x100W E27
+ 1x60W E14
CE IP20



Floor lamp
YOU 28
Max 2x100W E27
+ 1x60W E14
CE IP20

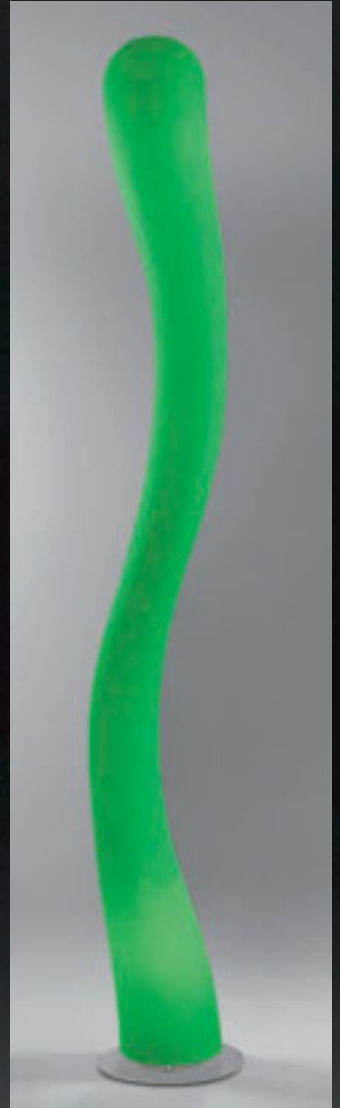

Floor lamp
YOU 10
Max 2x100W E27
+ 1x60W E14
CE IP20



Floor lamp
 YOU & ME 11
 Max 4x100W E27 
 + 2x60W E14 
 CE IP20  



Floor lamp
 YOU & ME 26
 Max 4x100W E27 
 + 2x60W E14 
 CE IP20  



Floor lamp
 YOU & ME 06
 Max 4x100W E27 
 + 2x60W E14 
 CE IP20  

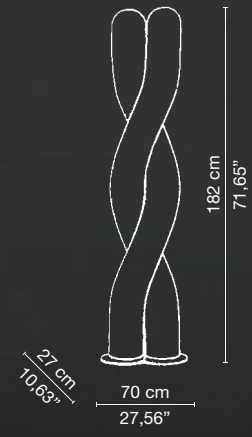

Floor lamp
YOU & ME 29
Max 4x100W E27
+ 2x60W E14
CE IP20



Floor lamp
YOU & ME 28
Max 4x100W E27
+ 2x60W E14
CE IP20



Floor lamp
YOU & ME 10
Max 4x100W E27
+ 2x60W E14
CE IP20

Petit Bouchon

Realizzato in polietilene atossico,
riciclabile al 100% e stabilizzato UVA.

Manufactured from UVA
stabilized non-toxic
polyethylene 100% recyclable.

Réalisé en polyethylene atoxique,
100% recyclable et stabilisé UVA

Aus ungiftigem Polyethylen gefertigt, zu
100% recyclebar und UVA-beständig.

Realizado en polietileno atóxico,
100% reciclable y estabilizado UVA.

Изготовлено из нетоксичного
полиэтилена, перерабатываемого
на 100% и стабилизированного
на проникновение
ультрафиолетового излучения.

74



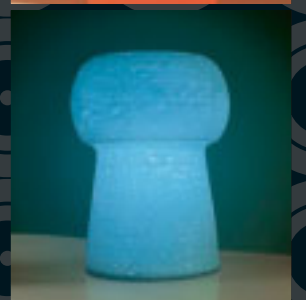

75

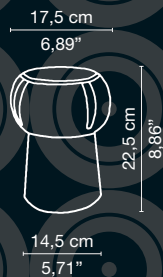

Table lamp
 PETIT BOUCHON ...
 Max 1x40W E14

Max 1x11W E14

01 06 10 11 26 28 29

CE IP20

Dado

La serie DADO è realizzata in metacrilato colato, nei colori satinato blu, arancio e trasparente con struttura in cromo spazzolato e particolari in cromo lucido.

The DADO collection is manufactured from cast methacrylate, colours available satin finish blue, orange and clear with a brushed chrome fixture and polished chrome detailing.

La série DADO est réalisée en méthacrylate moulé, dans les coloris satiné bleu, orange et transparent avec structure en chrome satiné et détails en chrome brillant.

Die Serie DADO ist aus gegossenem Methacrylat gefertigt, in den Farben blau satiniert, orange und transparent mit einer gebürsteten Chromaufbau und Details aus glänzendem Chrom.

La serie DADO está realizada de metacrilado de colada, en color satinado azul, anaranjado y transparente con estructura cromada cepillada con detalles en cromado brillante.

Серия DADO изготовлена из отлитого метакрилата в цветовой тональности: сатинированный синий, оранжевый и прозрачный, с конструкцией из полированного хрома и элементами из блестящего хрома.



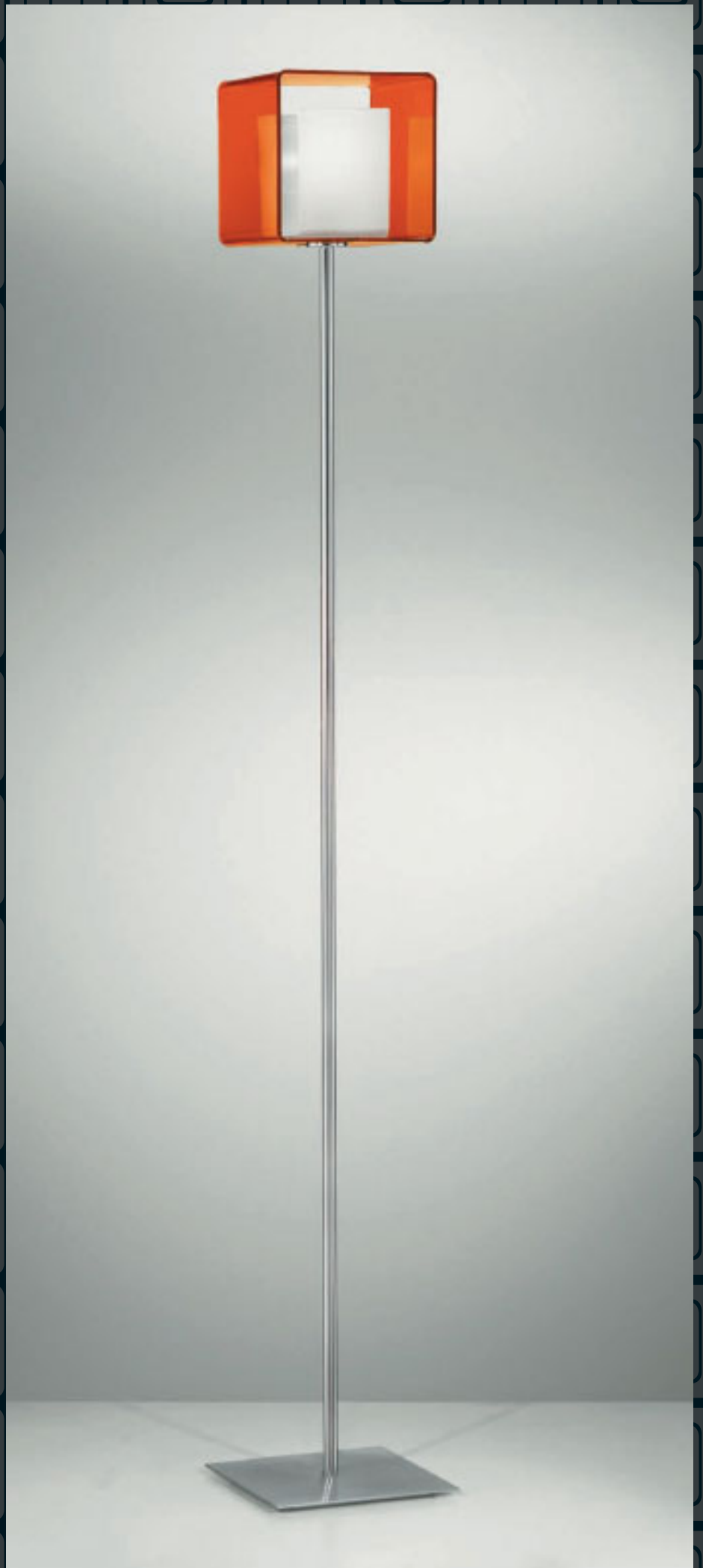

Floor lamp
D DADO PI 08...
Max 1x150W E27
■ 04 ■ 12 ■ 13 ■ 26
CE IP20





Pendant lamp

D DADO SO8 08...

Max 8x40W G9 

■ 04 ■ 12 ■ 13 ■ 26

CE IP20  

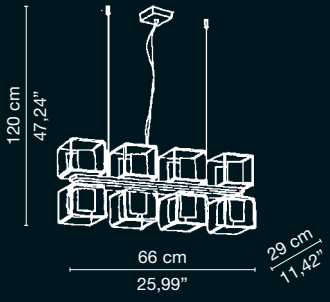





Pendant lamp

D DADO SO4 08...

Max 4x40W G9 

■ 04 ■ 12 ■ 13 ■ 26

CE IP20  

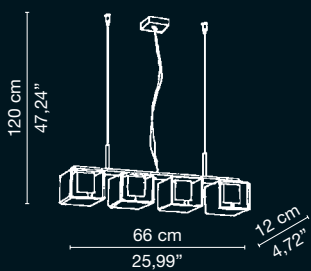







Pendant lamp

D DADO SO1 08...

Max 1x100W E27 

Max 1x23W E27  

■ 04 ■ 12 ■ 13 ■ 26

CE IP20  





Pendant lamp

D DADO SO2 08...

Max 1x40W G9 

■ 04 ■ 12 ■ 13 ■ 26

CE IP20  

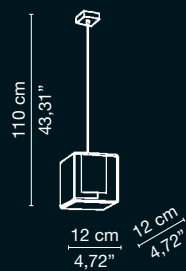





Ceiling lamp

D DADO PL2 08...

Max 2x40W G9 

■ 04 ■ 12 ■ 13 ■ 26

CE IP20  





Ceiling lamp

D DADO PL4 08...

Max 4x40W G9

■ 04 ■ 12 ■ 13 ■ 26

CE IP20

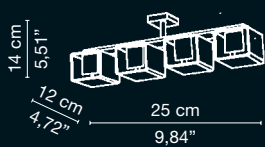





Wall lamp

D DADO AP1 08...

Max 1x40W G9 

■ 04 ■ 12 ■ 13 ■ 26

CE IP20  

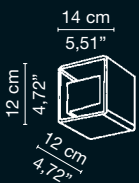



Wall lamp

D DADO AP2 08...

Max 2x40W G9 

■ 04 ■ 12 ■ 13 ■ 26

CE IP20  

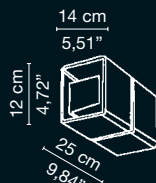



Wall lamp

D DADO AP 08...

Max 1x40W G9

■ 04 ■ 12 ■ 13 ■ 26

CE IP20

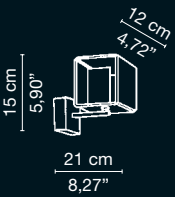

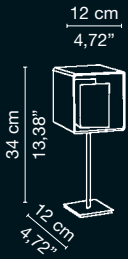

Table lamp

D DADO LTB 08...

Max 1x40W G9

■ 04 ■ 12 ■ 13 ■ 26

CE IP20

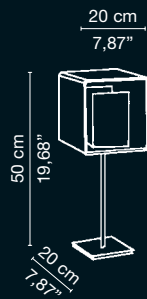

Table lamp

D DADO LTA 08...

Max 1x100W E27

Max 1x23W E27

■ 04 ■ 12 ■ 13 ■ 26

CE IP20





Desk lamp

D DADO LUB 08...

Max 1x40W G9

04 12 13 26

CE IP20

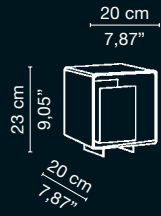

Desk lamp

D DADO LUA 08...

Max 1x100W E27

Max 1x23W E27

04 12 13 26

CE IP20



Riflessi

Plexiglass e vetro cattedrale, ambra
o blu e lastra acidata extra chiaro.
Lampadine incluse.

Plexiglas and cathedral glass, amber or
blue with an ultra-clear etched plate.
Light bulbs included.

Plexiglas et verre cathédrale,
ambre et bleu et verre très clair en
feuille traité à l'acide.
Ampoules incluses.

88

Plexiglas und Kathedralenglas in
Bernstein oder Blau und extraklarem,
gehärteten Scheibenglas.
Inklusive Glühbirnen.

Plexiglás y vidrio catedral, ámbar o azul
y lámina tratada al ácido extraclara.
Bombillas incluida.

Плексиглас и мозаичное стекло,
янтарное или синее, и протравленная
кислотой высветленная
металлическая пластина.
Лампочки включены.



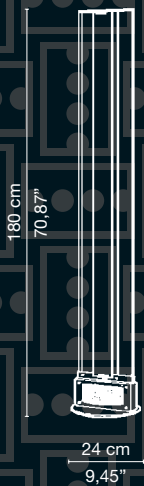
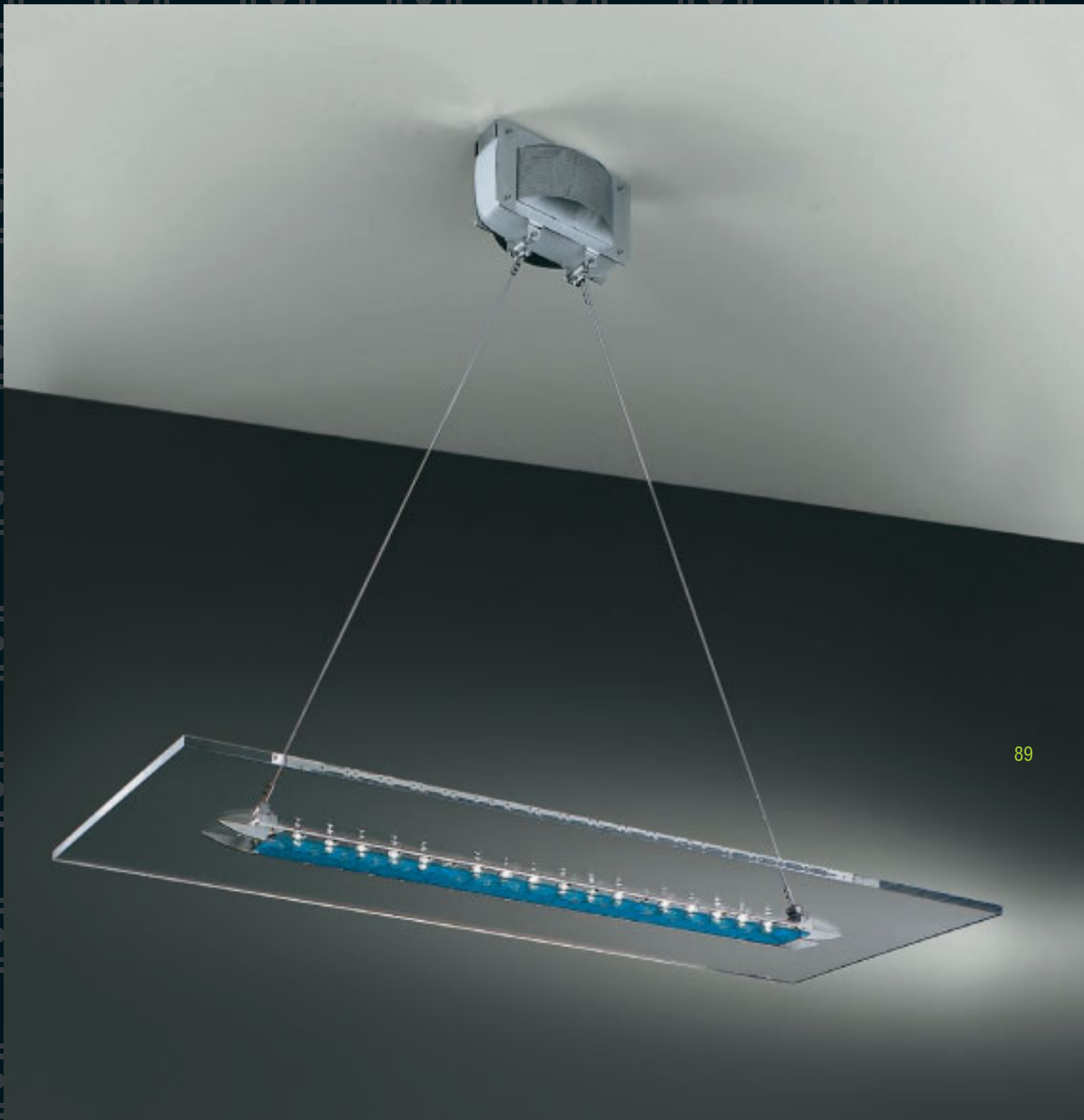

Floor lamp

D RIF PI 16...

Max 15x21W SV 8,5-8

02 12 13

CE IP20

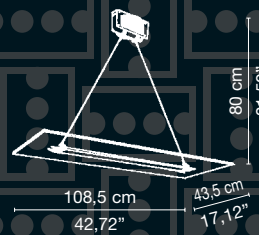

Pendant lamp

D RIF SO1 16...

Max 16x21W SV 8,5-8

02 12 13

CE IP20

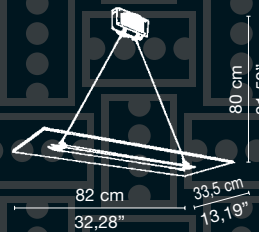

Pendant lamp

D RIF SO2 16...

Max 12x21W SV 8,5-8

02 12 13

CE IP20



Table lamp

D RIF LT 16...

Max 7x21W SV 8,5-8

02 12 13

CE IP20



90



Ceiling lamp

D RIF PL1 16...

Max 16x21W SV 8,5-8

02 12 13

CE IP20

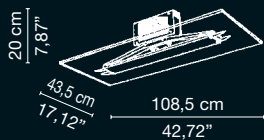

Ceiling lamp

D RIF PL2 16...

Max 12x21W SV 8,5-8

02 12 13

CE IP20

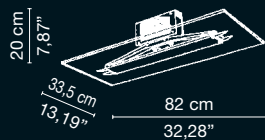



Ocean

Lampada in bassa tensione
realizzata con vetri in lastra
extra chiara e acciaio satinato.

Low voltage lamp made
with ultra-clear glass
plate and satin steel.

Lampe en basse tension
fabriquée avec du verre très clair
en feuille et de l'acier satiné.

Niedrigvoltlampe aus
extraklarem Scheibenglas
und mattiertem Stahl.

Lámpara de baja tensión
realizada con láminas de vidrio
extraclaras y acero satinado.

Лампа низкого напряжения,
изготовленная из осветленного
листового стекла и
сатинированной стали.



92

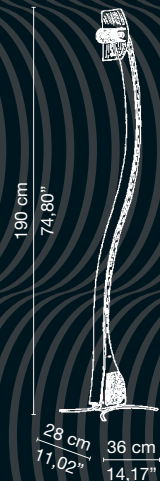

Floor lamp



D OCE PI 13A testa in metallo

Max 11x21W SV 8,5-8 

(Lampadine incluse - Light bulbs supplied)

Max 2x35W GY 6,35 

(Lampadine non incluse - Light bulbs not supplied)

CE IP20  

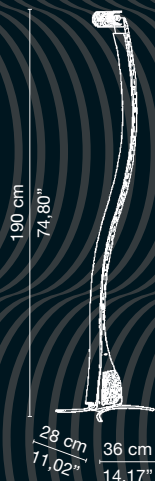
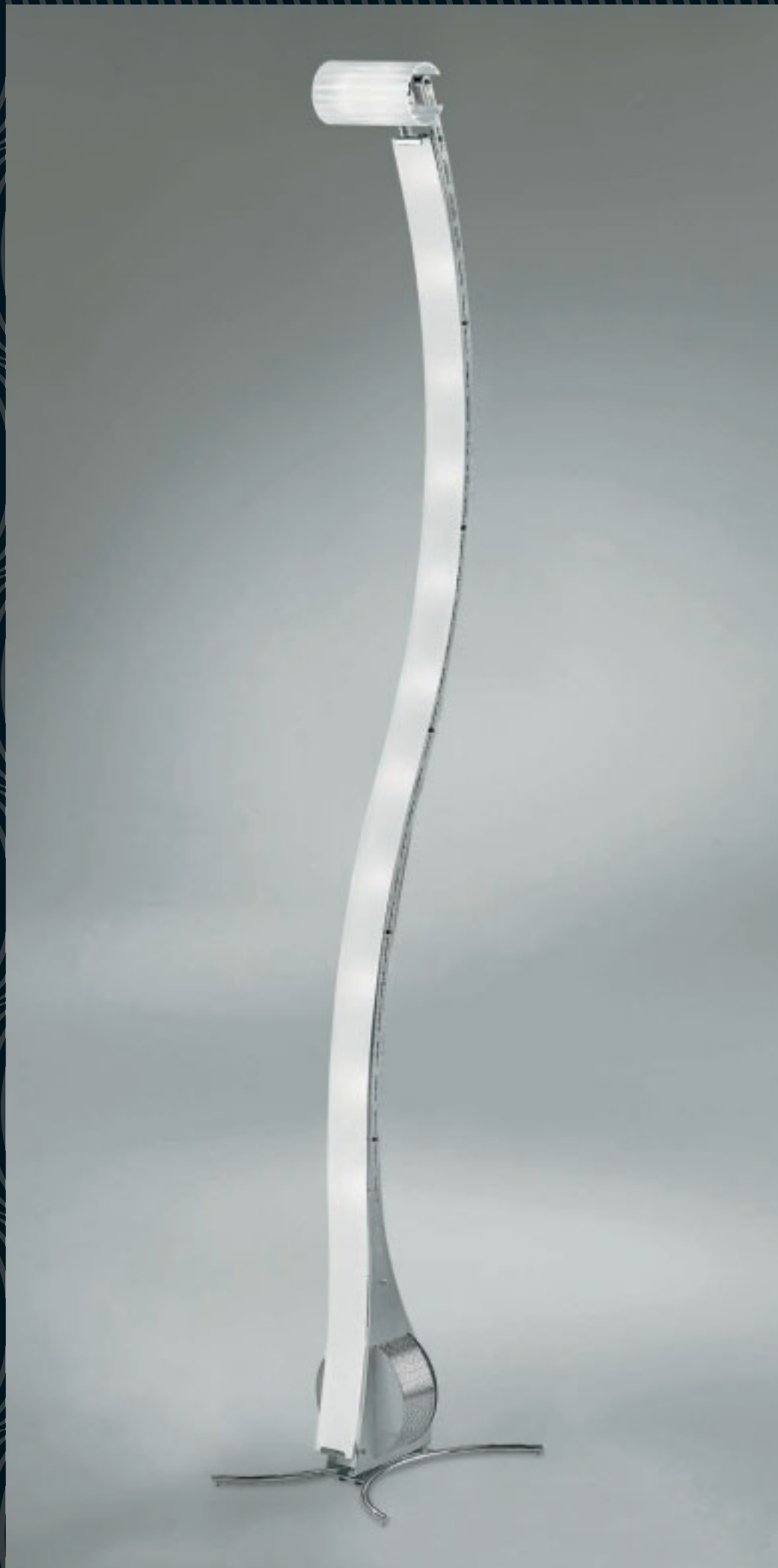

Floor lamp

D OCE PI 13 testa in vetro

Max 11x21W SV 8,5-8

(Lampadine incluse - Light bulbs supplied)

Max 2x35W GY 6,35

(Lampadine non incluse - Light bulbs not supplied)

CE IP20





**Pendant lamp**

D OCE SO1 16 13

Max 16x21W SV 8,5-8 

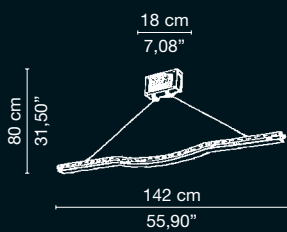
(Lampadine incluse - Light bulbs supplied)

CE IP20  

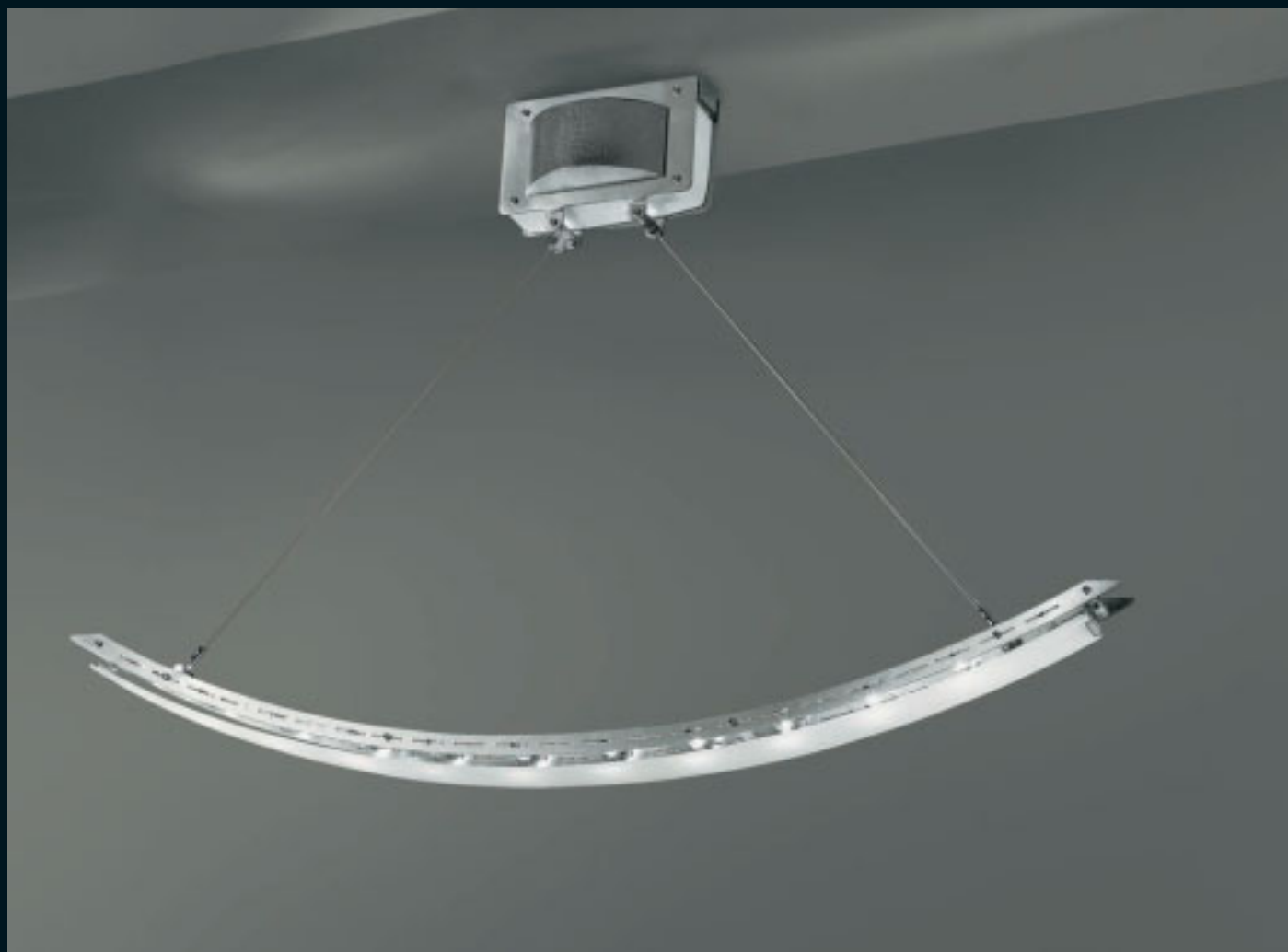

Pendant lamp

D OCE SO2 16 13

Max 12x21W SV 8,5-8

(Lampadine incluse - Light bulbs supplied)

CE IP20

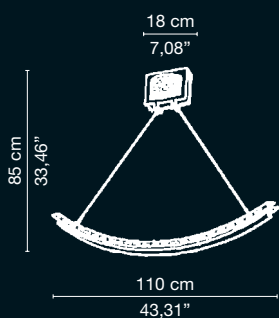

Ceiling lamp

D OCE PL1 16 13

Max 16x21W SV 8,5-8

(Lampadine incluse - Light bulbs supplied)

CE IP20

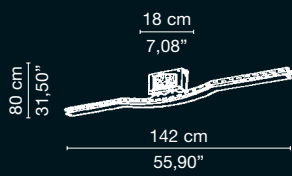

96



Ceiling lamp

D OCE PL2 16 13

Max 12x21W SV 8,5-8

(Lampadine incluse - Light bulbs supplied)

CE IP20

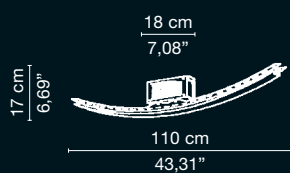



Wall lamp

D OCE AP 16 13

Max 5x40W G9

(Lampadine non incluse - Light bulbs not supplied)

CE IP20



Land

Lampada in vetro Pirex con struttura in acciaio cromato e rete traforata.

Pirex glass lamp with chrome plated steel structure and fretted net.

98

Lampe en pyrex avec structure en acier chromé et grillage perforé.

Lampe aus Pyrex-Glas mit tragenden Teilen aus verchromtem Stahl und durchlöcherter Netz.

Lámpara de vidrio Pyrex con estructura de acero cromado y rejilla perforada.



Лампа из стекла пирекс с конструкцией из хромированной стали и перфорированной сетки.



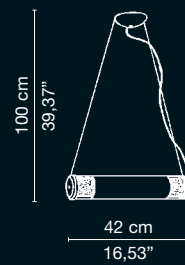

Floor lamp
D LAND PI 16 13
Max 4x50W GU10 
CE IP40  





Pendant lamp
D LAND SO 16 13
Max 1x150W R7s 
CE IP20 



101



Wall lamp
D LAND AP 16 13
Max 1x50W GU10 
CE IP30  



102



Table lamp
D LAND LT 16 13
Max 1x50W GU10 
CE IP40  



Aly

Vetro extrachiaro rifinito con bordo lucido, struttura in metallo cromato.

Ultra-clear glass finished with a polished border, chrome-plated metal structure.

104

Verre très clair fini avec un bord brillant, structure en métal chromé.

Extrklares Glas mit Hochglanzrand, tragende Teile aus verchromtem Metall.

Vidrio extraclaro acabado con borde brillante, estructura de metal cromado.

Высветленное стекло с отделкой блестящей каймой, конструкция из хромированного металла.





105

Pendant lamp

D ALY SO1 1613

Max 1x200W R7s



Pendant lamp

D ALY SO1 A 1613

Max 2x24W G5

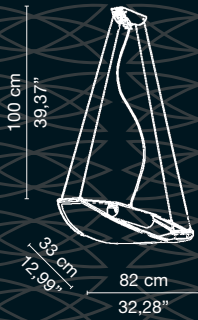

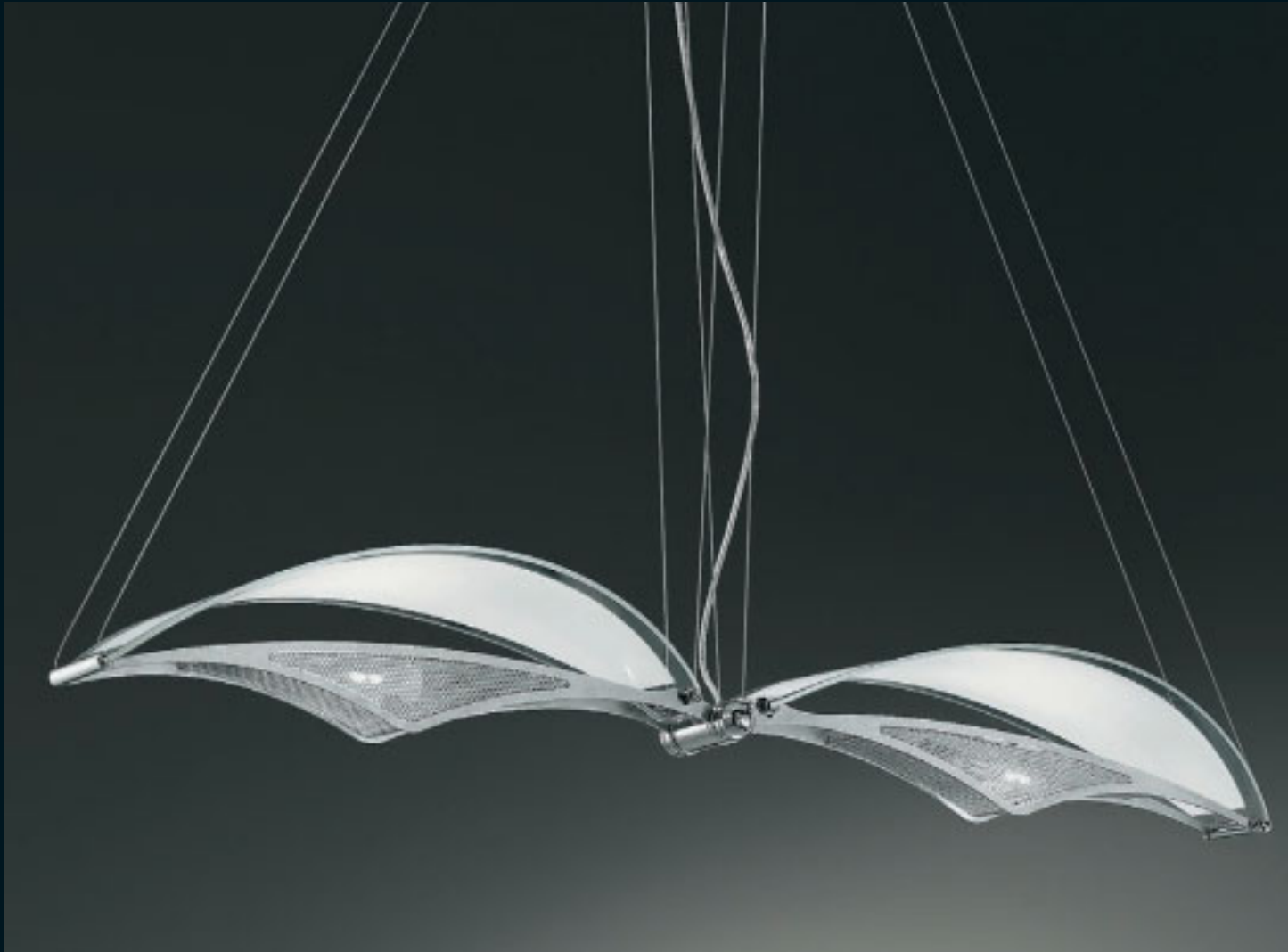



Pendant lamp

D ALY SO2 1613



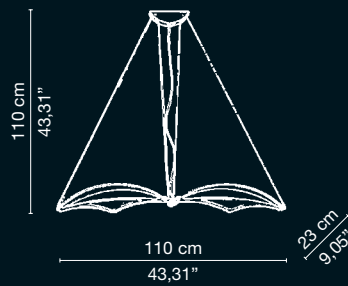

Max 2x100W E14  halogen

 IP20  





Ceiling lamp

D ALY PL1 1613

 Max 1x150W R7s 
 IP20  

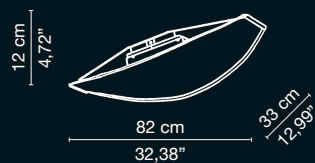
D ALY PL1 A 1613

 Max 2x24W G5 
 IP20   







Wall lamp

D ALY AP2 1613

Max 1x150W R7s 

CE IP20 



Wall lamp

D ALY AP1 1613

Max 1x150W R7s 

CE IP20 

D ALY AP1 A 1613

Max 1x26W G24d-3 

CE IP20  

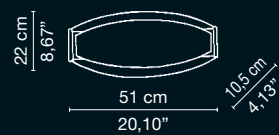

Vetro extrachiaro rifinito con bordo lucido, struttura in metallo cromato.

Ultra-clear glass finished with a polished border, chrome-plated metal structure.

110

Verre très clair fini avec un bord brillant, structure en métal chromé.

Extraklares Glas mit Hochglanzrand, tragende Teile aus verchromtem Metall.

Vidrio extraclaro acabado con borde brillante, estructura de metal cromado.

Высветленное стекло с отделкой блестящей каймой, конструкция из хромированного металла.





Pendant lamp

D IRI SO1 1613

Max 1x200W R7s

CE IP20

D IRI SO1 A 1613

Max 2x24W G5

CE IP20



Pendant lamp

D IRI SO2 1613

Max 1x200W R7s

CE IP20

D IRI SO2 A 1613

Max 2x24W G5

CE IP20

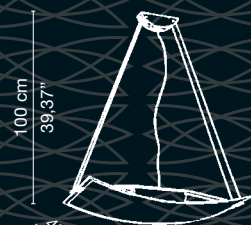





Ceiling lamp

D IRI PL1 1613

Max 1x150W R7s 

CE IP20 

D IRI PL1 A 1613

Max 2x24W G5 

CE IP20  

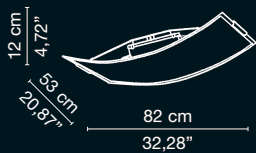

Ceiling lamp

D IRI PL2 1613

Max 1x150W R7s 

CE IP20 

D IRI PL2 A 1613

Max 2x24W G5 

CE IP20  

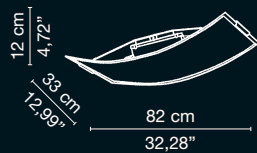

Ceiling lamp

D IRI PL3 1613

Max 1x150W R7s 

CE IP20 

D IRI PL3 A 1613

Max 2x24W G5 

CE IP20  

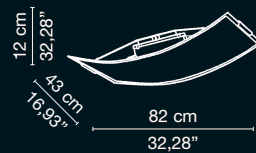









Wall lamp

D IRI AP 1613

 Max 1x150W R7s 

 CE IP20 

D IRI AP A 1613

 Max 1x26W G24d-3 

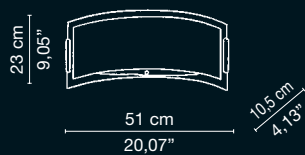
 CE IP20  

Wall lamp

D IRI AP2 1613

 Max 1x150W R7s 

 CE IP20 

116

Vetro extrachiaro liscio o rigato.

Ultra-clear smooth or scored glass.

Verre très clair lisse ou rainuré.

Extrklares Glas, glatt oder mit Rillen.

Vidrio extraclaro liso o con rayas.

Гладкое высветленное или
рифленое стекло.

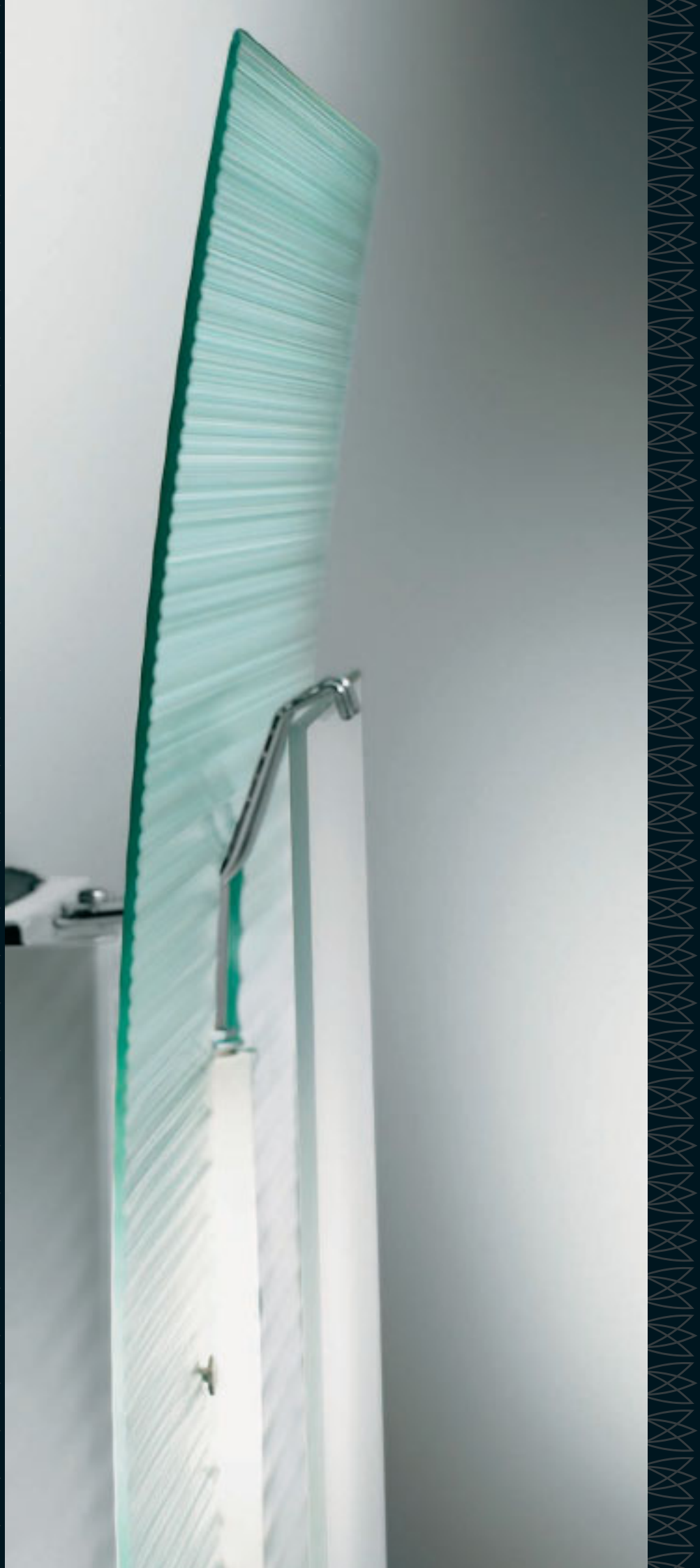

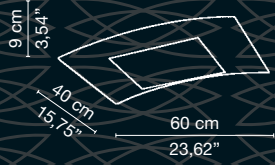

Ceiling lamp
 D MAYA PL 1604
 Max 1x150W R7s 
 CE IP20  

Ceiling lamp
 D MAYA PL A 1604
 Max 2x18 G24d-2 
 CE IP20   

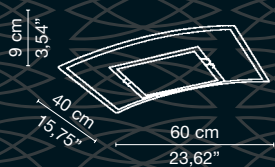

Ceiling lamp
 D MAYA PL 1613
 Max 1x150W R7s 
 CE IP20  

Ceiling lamp
 D MAYA PL A 1613
 Max 2x18 G24d-2 
 CE IP20   

Tribal

Vetro extrachiaro serigrafato,
rifinito con bordo lucido,
struttura in metallo cromato.

Extra-clear silk-screen
printed glass with a polished rim,
chrome plated metal fixture.

Verre extra clair serigraphé,
fini avec un bord brillant,
structure en métal chromé.

Extra helles Siebdruckglas,
mit glänzendem Rand
fertigbearbeitet, Metallaufbau.

Vidrio extraclaro serigrafiado,
acabado con borde brillante,
estructura de metal.

Высветленное
сериграфированное стекло с
отделкой блестящей каймой,
металлическая конструкция.





Pendant lamp

TRIBAL S02 01 ■

TRIBAL S02 32 ■

Max 1x200W R7s ←

CE IP20 ▽ ⊕

Pendant lamp

TRIBAL S02 A 01 ■

TRIBAL S02 A 32 ■

Max 2x24W G5 ←

CE IP20 ▽ ⊕ **ES**

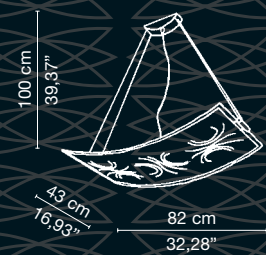





Ceiling lamp

TRIBAL PL3 01 ■

TRIBAL PL3 32 ■

Max 1x150W R7s 

CE IP20  

Ceiling lamp

TRIBAL PL3 A 01 ■

TRIBAL PL3 A 32 ■

Max 2x24W G5 

CE IP20   









Wall lamp

TRIBAL AP 01 ■

TRIBAL AP 32 ■

Max 1x150W R7s

CE IP20

TRIBAL AP A 01 ■

TRIBAL AP A 32 ■

Max 1x26W G24d-3

CE IP20



Wall lamp

TRIBAL AP2 01 ■

TRIBAL AP2 32 ■

Max 1x150W R7s

CE IP20



Sound

Vetro extrachiaro serigrafato,
rifinito con bordo lucido,
struttura in metallo cromato.

Extra-clear silk-screen
printed glass with a polished rim,
chrome plated metal fixture.

Verre extra clair serigraphé,
fini avec un bord brillant,
structure en métal chromé.

Extra helles Siebdruckglas, mit
glänzendem Rand fertigbearbeitet,
verchromter Metallaufbau.

Vidrio extraclaro serigrafiado,
acabado con borde brillante,
estructura de metal cromado.

Высветленное сериграфированное
стекло с отделкой блестящей
каймой, конструкция из
хромированного металла.





125



Pendant lamp

SOUND S02 00

SOUND S02 11

SOUND S02 10

Max 1x200W R7s 

CE IP20   

Pendant lamp

SOUND S02 A 00

SOUND S02 A 11

SOUND S02 A 10

Max 2x24W G5 

CE IP20    

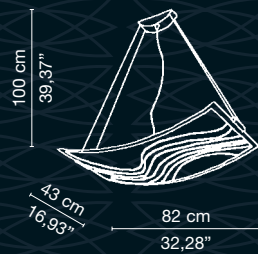

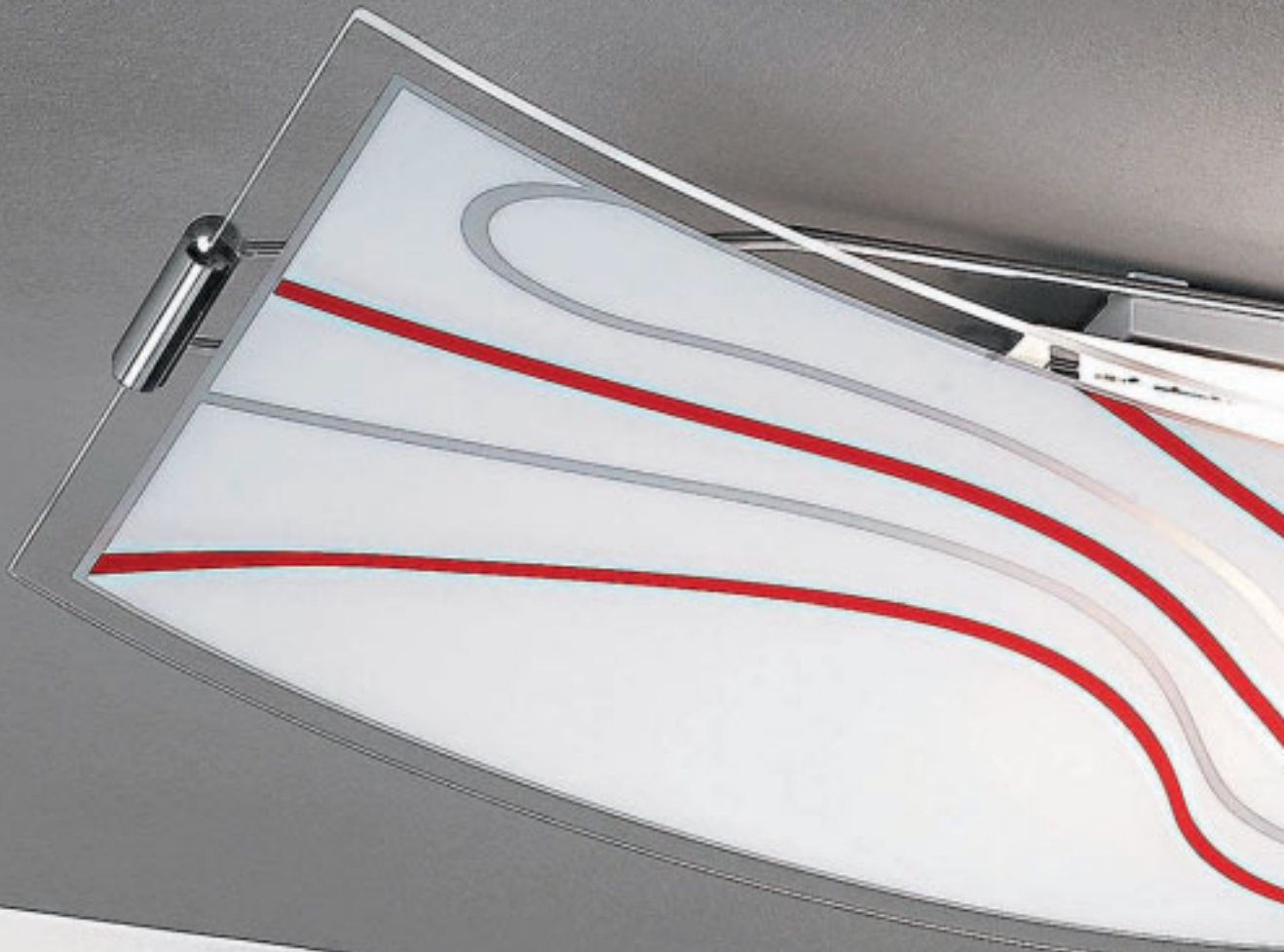

Ceiling lamp

- SOUND PL3 00
- SOUND PL3 11
- SOUND PL3 10
- Max 1x150W R7s

CE IP20

Ceiling lamp

- SOUND PL3 A 00
- SOUND PL3 A 11
- SOUND PL3 A 10
- Max 2x24W G5

CE IP20

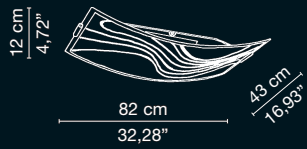







Wall lamp

- SOUND AP 00
- SOUND AP 11
- SOUND AP 10
- Max 1x150W R7s
- CE IP20

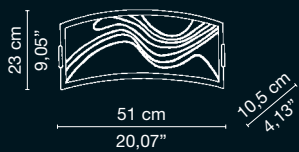

Wall lamp

- SOUND AP A 00
- SOUND AP A 11
- SOUND AP A 10
- Max 1x26W G24d-3
- CE IP20

Wall lamp

- SOUND AP2 00
- SOUND AP2 11
- SOUND AP2 10
- Max 1x150W R7s
- CE IP20

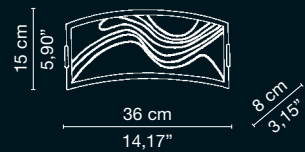

Vetro extrachiaro serigrafato,
rifinito con bordo lucido,
struttura in metallo cromato.

Extra-clear silk-screen
printed glass with a polished rim,
chrome plated metal fixture.

Verre extra clair serigraphé,
fini avec un bord brillant,
structure en métal chromé.

Extra helles Siebdruckglas, mit
glänzendem Rand fertigbearbeitet,
verchromter Metallaufbau.

Vidrio extraclaro serigrafiado,
acabado con borde brillante,
estructura de metal cromado.

Высветленное сериграфированное
стекло с отделкой блестящей
каймой, конструкция из
хромированного металла.

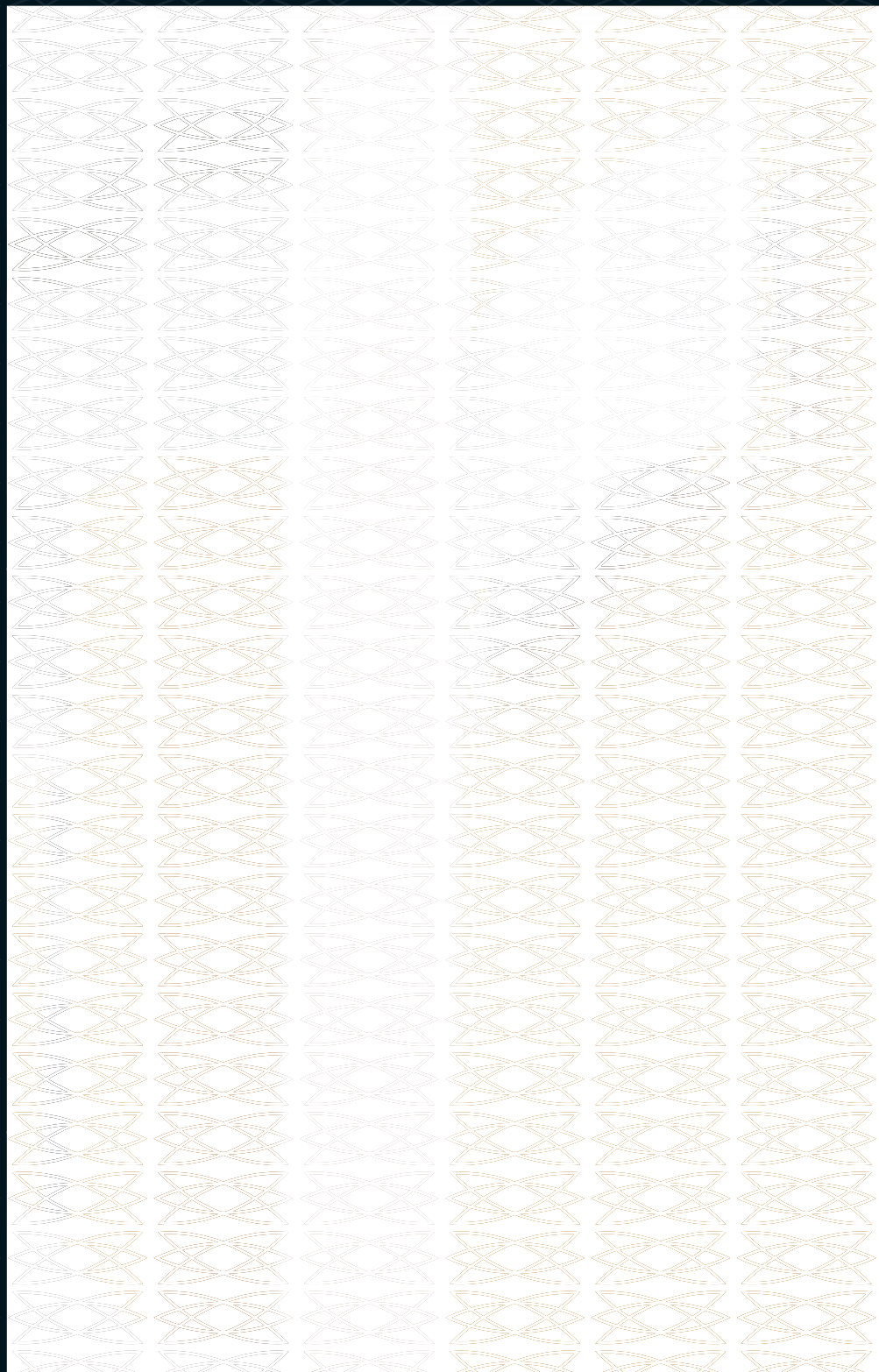





Pendant lamp

CHI S02 01 ■

CHI S02 26 ■

Max 1x200W R7s 

CE IP20  

Pendant lamp

CHI S02 A 01 ■

CHI S02 A 26 ■

Max 2x24W G5 

CE IP20   

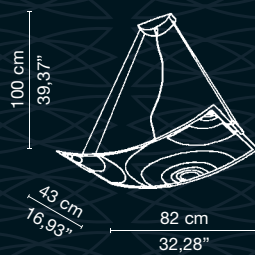





Ceiling lamp

CHI PL3 01 ■

CHI PL3 26 ■

Max 1x150W R7s 

CE IP20  

Ceiling lamp

CHI PL3 A 01 ■

CHI PL3 A 26 ■

Max 2x24W G5 

CE IP20   









Wall lamp

CHI AP 01 ■

CHI AP 26 ■

Max 1x150W R7s

CE IP20

CHI AP A 01 ■

CHI AP A 26 ■

Max 1x26W G24d-3

CE IP20



Wall lamp

CHI AP2 01 ■

CHI AP2 26 ■

Max 1x150W R7s

CE IP20



Circle

Vetro extrachiaro serigrafato,
rifinito con bordo lucido,
struttura in metallo cromato.

Extra-clear silk-screen
printed glass with a polished rim,
chrome plated metal fixture.

Verre extra clair serigraphé,
fini avec un bord brillant,
structure en métal chromé.

136

Extra helles Siebdruckglas, mit
glänzendem Rand fertigbearbeitet,
verchromter Metallaufbau.

Vidrio extraclaro serigrafiado,
acabado con borde brillante,
estructura de metal cromado.

Высветленное сериграфированное
стекло с отделкой блестящей
каймой, конструкция из
хромированного металла.



Ceiling lamp

CIRCLE PL 01 ■

Max 5x60W E27



70 cm

27,56"

Ceiling lamp

CIRCLE PL2 01 ■



Max 2x60W E14







41 cm

16,14"

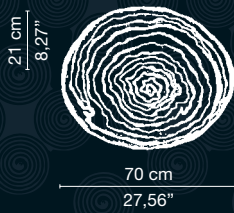

Ceiling lamp
CIRCLE PL 00
Max 5x60W E27 
CE IP20  



Ceiling lamp
CIRCLE PL2 00
Max 2x60W E14 
CE IP20  

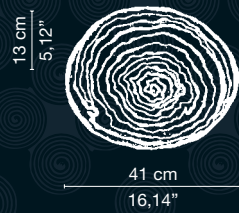

Crystal

138

Vetro pirex soffiato,
liscio o rigato.

Blown pirex glass,
smooth or scored finish.

Pyrex soufflé,
lisse ou rainuré.

Gebblasenes Pyrexglas,
glatt oder mit Rillen.

Vidrio pyrex soplado,
liso o con rayas.

Выдувное гладкое или
рифленое стекло пирекс.





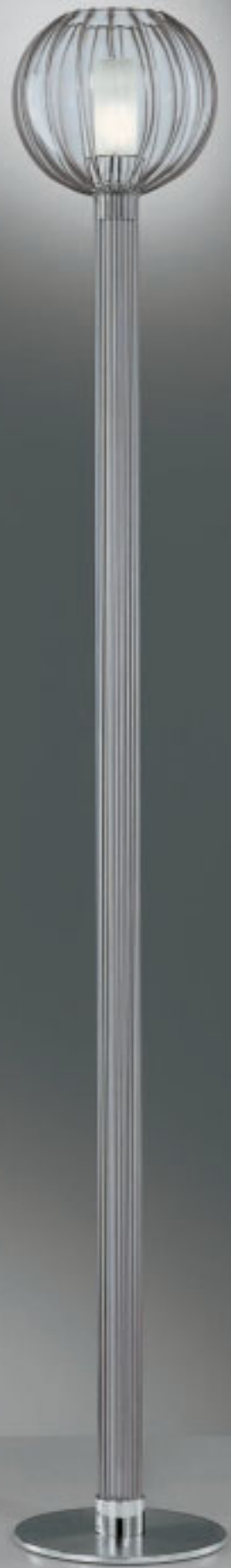
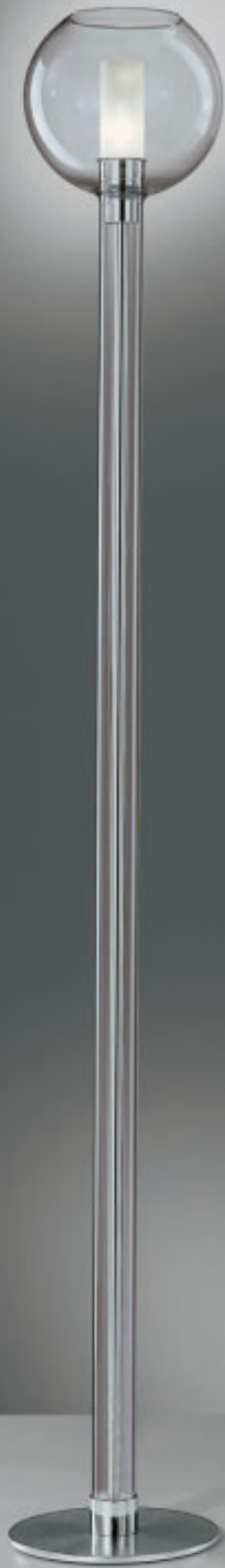

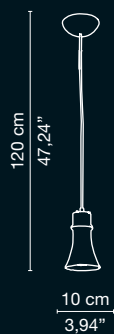

Pendant lamp
 D CRI SO 16...
 Max 1x100W E14 halogen
 CE IP20
 Da completare con sorgenti pag 142
 To be completed with the light sources given on page 142



Pendant lamp
 D CRI SO 16...
 Max 1x100W E14 halogen
 CE IP20
 Da completare con sorgenti pag 142
 To be completed with the light sources given on page 142



Floor lamp
 D CRI PI 1604
 Max 1x250W E14 halogen
 CE IP20



Floor lamp
 D CRI PI 1604R
 Max 1x250W E14 halogen
 CE IP20



142



Sistema di composizione - Sorgenti

Composition system - End finishing

Sfere - Globes

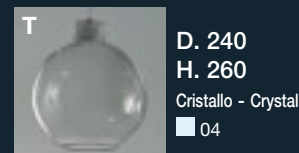

T
D. 240
H. 260
Cristallo - Crystal
■ 04



TR
D. 240
H. 260
Cristallo - Crystal
■ 04

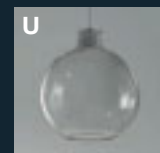

U
D. 170
H. 180
Cristallo - Crystal
■ 04

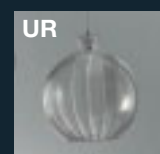

UR
D. 170
H. 180
Cristallo - Crystal
■ 04

Sorgenti - End finishing

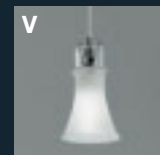

V
D. 100
H. 150
Acidato - Frosted
■ 13

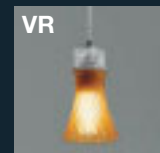

VR
D. 100 - H. 150
Cristallo - Crystal
■ 04
Ambra tr. - Amber
■ 02



Z
D. 65
H. 180
Acidato - Frosted
■ 13



ZR
D. 65 - H. 180
Cristallo - Crystal
■ 04
Ambra tr. - Amber
■ 02

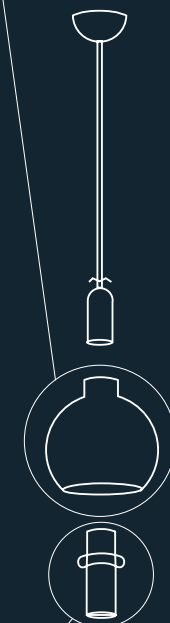

N.B.: Tutte le misure degli articoli del tecnico (altezza H, larghezza L, sporgenza - profondità sp/P) non tengono conto delle sorgenti luminose.

N.B.: All measurement of the technical items (height H, width L, protrusion - depth sp/P) do not take into consideration the end finishings.

Pendant lamp

D CRI SO 16...

Max 1x100W E14 halogen

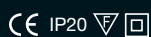

Da completare con sorgenti

To be completed with the light sources

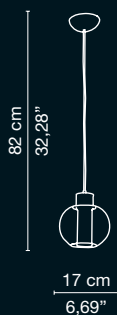

Pendant lamp

D CRI SO 16...

Max 1x100W E14 halogen

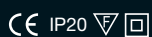

Da completare con sorgenti

To be completed with the light sources









143

Wall lamp

D CRI AP 16...

Max 1x100W E14  halogen

 IP20  

Da completare con sorgenti pag 142

To be completed with the light sources
given on page 142

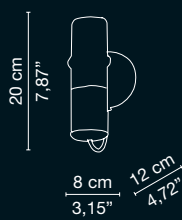





Desk lamp
D CRI LU 1604
D CRI LU 1604R
Max 1x100W E14 halogen
CE IP20



Table lamp
D CRI LT 1604
D CRI LT 1604R
Max 1x150W E14 halogen
CE IP20



Vetro in lastra extrachiaro satinata,
e vetro cattedrale satinato nei
colori ambra o blu, struttura bianca
con particolari cromo lucido.

Extra-clear satin finish plate glass and
satin finish cathedral glass colours
available amber or blue, white fixture
with polished chrome detailing.

Verre très clair en feuille et verre
cathédrale ambre ou bleu,
monture en métal peint blanc avec
détails chrome brillant.

Glas aus extra hellem satinierten
Flach- und Kathedralglas in den Farben
Bernstein oder Blau, weißer Aufbau mit
glänzenden Chromdetails.

146

Lámina de vidrio extraclara satinada,
y vidrio catedral satinado de color
ámbar o azul, estructura blanca con
detalles en cromado brillante.

Стекло из высветленной
сатинированной пластины и
сатинированное мозаичное стекло
янтарного или синего цвета, белая
конструкция с элементами из
блестящего хрома.





147





Pendant lamp

D LINK2 SO9 16...

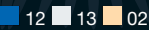
Max 1x300W R7s 

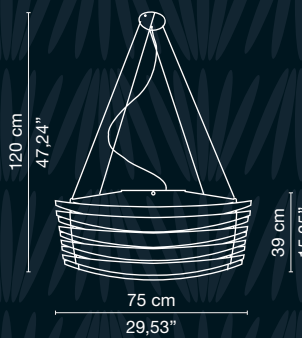

 12 13 02

 IP20  

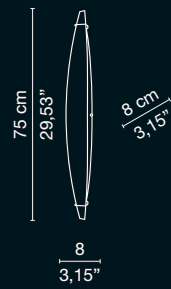

148



Wall lamp
D LINK2 AP1 16...
Max 1x150W R7s 114 
■ 13 ■ 02 ■ 12
CE IP20  

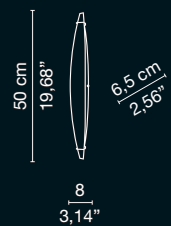

Wall lamp
D LINK AP1 16...
Max 1x100W R7s 78 
■ 13 ■ 02 ■ 12
CE IP20  



Wall / Ceiling lamp

D LINK2 AP3 16...
D LINK2 PL3 16...
Max 1x200W R7s 114

Halogen

CE IP20

D LINK2 AP3 A 16...
D LINK2 PL3 A 16...

Max 1x24W 2G11

■ 13 ■ 02 ■ 12

CE IP20

Wall / Ceiling lamp

D LINK AP3 16...
D LINK PL3 16...
Max 1x150W R7s 80

Halogen

CE IP20

D LINK AP3 A 16...
D LINK PL3 A 16...

Max 1x18W 2G11

■ 13 ■ 02 ■ 12

CE IP20

Wall / Ceiling lamp

D LINK2 AP7 16...
D LINK2 PL7 16...
Max 1x200W R7s

Halogen

CE IP20

D LINK2 AP7A 16...
D LINK2 PL7 A 16...

Max 2x24W 2G11

■ 13 ■ 02 ■ 12

CE IP20

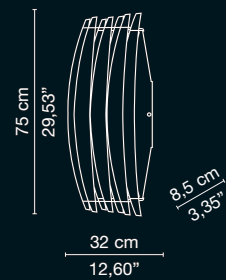
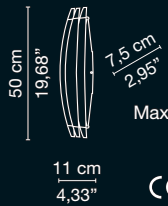
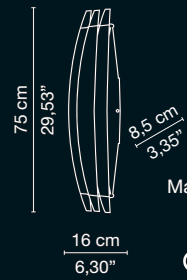

Wall / Ceiling lamp

D LINK2 AP5 16... / D LINK2 PL5 16...

Max 1x200W R7s 114 Halogen

D LINK2 AP5 A 16... / D LINK2 PL5 A 16...

Max 2x24W 2G11

■ 13 ■ 02 ■ 12

CE IP20

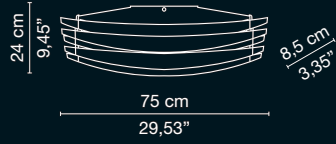

Wall / Ceiling lamp

D LINK AP5 16... / D LINK PL5 16...

Max 1x150W R7s 114 Halogen

D LINK AP5 A 16... / D LINK PL5 A 16...

Max 2x18W 2G11

■ 13 ■ 02 ■ 12

CE IP20

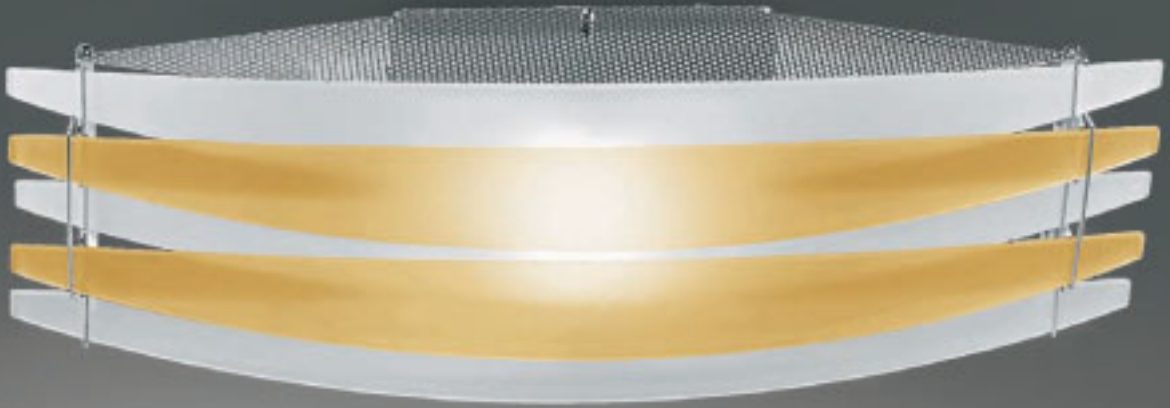
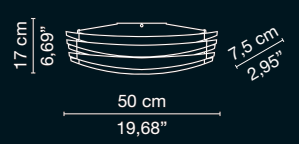

Wall / Ceiling lamp

D LINK2 AP9 16... / D LINK2 PL9 16...

Max 1x200W R7s 114 Halogen

D LINK2 AP9 A 16... / D LINK2 PL9 A 16...

Max 4x24W 2G11

■ 13 ■ 02 ■ 12

CE IP20

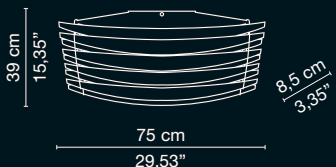

Wall / Ceiling lamp

D LINK AP9 16... / D LINK PL9 16...

Max 1x150W R7s 114 Halogen

D LINK AP9 A 16... / D LINK PL9 A 16...

Max 4x18W 2G11

■ 13 ■ 02 ■ 12

CE IP20

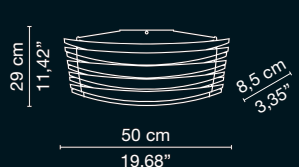



Ricamo

Struttura in metallo con finiture cromo,
vetro extrachiario curvato e serigrafato.

Chrome finish metal fixture,
extra-clear curved glass diffuser with
silk-screen printed finish.

Monture en métal avec finitions chrome,
verre très clair courbé et serigraphé.

Metallaufbau mit Chromfinishes,
extra helles gebogenes
Glas und Siebdruckglas.

152

Estructura de metal con acabado
en cromo, vidrio extraclaro curvado
y serigrafiado.

Металлическая конструкция с
хромированной отделкой,
изогнутое сериграфированное
высветленное стекло.









Pendant lamp

D RIC SOB 16 22

Max 1x150W E27

CE IP20  

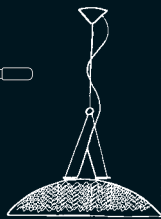



H min 57 max 110 cm
H min 22,44" max 43,31"

70 cm
27,56"

Pendant lamp

D RIC SO1B 16 22

Max 1x100W E27

CE IP20  





H min 57 max 110 cm
H min 22,44" max 43,31"

51 cm
20,08"

Pendant lamp

D RIC SO2B 16 22

Max 1x100W E27

CE IP20  



H min 57 max 110 cm
H min 22,44" max 43,31"

41 cm
16,14"



Pendant lamp
D RIC SOA 08 22
Max 3x100W E27

CE IP20



H min 70 max 100 cm
H min 27,56" max 39,37"

Pendant lamp
D RIC SO1A 08 22
Max 1x100W E27

CE IP20



H min 70 max 100 cm
H min 27,56" max 39,37"

Pendant lamp
D RIC SO2A 08 22
Max 1x100W E27

CE IP20

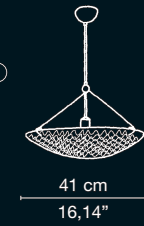

H min 70 max 100 cm
H min 27,56" max 39,37"



156



Ceiling lamp

D RIC PL 08 22

Max 5x60W E27

CE IP20



70 cm
27,56"

Ceiling lamp

D RIC PL1 08 22

Max 3x60W E27

CE IP20



51 cm
20,08"

Ceiling lamp

D RIC PL2 08 22

Max 2x60W E14



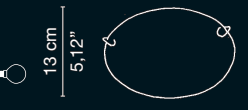

CE IP20



41 cm
16,14"

**Wall lamp**

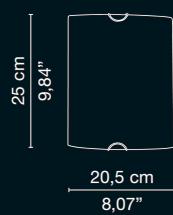
D RIC AP 08 22

Max 1x100W E27 CE IP20  

Struttura in cromo satinato,
con particolari cromo lucido,
vetro extrachiario satinato.

Satin finish chrome fixture
with polished chrome detailing.
Extra-clear satin finish glass diffuser.

Monture en chrome satiné,
avec détails chrome brillant,
verre satiné extra-clair.

158

Aufbau aus satiniertem Chrom
mit glänzenden Chromdetails.
Extra helles satiniertes Glas.

Estructura de cromo satinado,
con detalles en cromado brillante.
Vidrio extraclaro satinado.

Конструкция из сатинированного
хрома с элементами из блестящего
хрома. Высветленное
сатинированное стекло.







Pendant lamp

D VENE SOB 1613

Max 1x150W E27 



CE IP20  



Pendant lamp

D VENE SO1B 1613

Max 1x100W E27 

CE IP20  



Pendant lamp

D VENE SO2B 1613

Max 1x100W E27 

CE IP20  







Pendant lamp

D VENE SOA 0813

Max 3x100W E27 

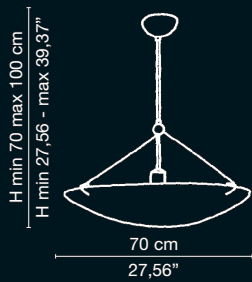

CE IP20  



Pendant lamp

D VENE SO1A 0813

Max 1x100W E27 

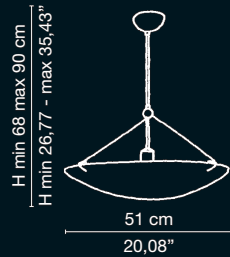

CE IP20  



Pendant lamp

D VENE SO2A 0813

Max 1x100W E27 

CE IP20  

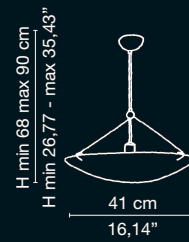

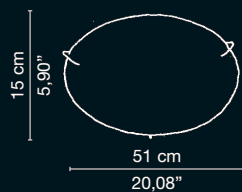

Ceiling lamp

D VENE PL 0813

Max 5x60W E27

CE IP40

Ceiling lamp

D VENE PL1 0813

Max 3x60W E27

CE IP40

Ceiling lamp

D VENE PL2 0813

Max 2x60W E14

CE IP40



Goccia

Struttura in metallo cromato
con finitura lucida e satinata,
vetro fatto a mano e satinato.

Chrome plated metal fixture with
a satin and polished finish,
handcrafted satin finish glass diffuser.

Monture en métal chromé
avec finition brillante et satinée,
verre artistique satiné.

162

Aufbau aus verchromtem Metall mit
glänzendem und satiniertem Finish,
handgefertigtes und satiniertes Glas.

Estructura de metal cromado con
acabado brillante y satinado.
Vidrio hecho a mano y satinado.

Конструкция из хромированного
стекла с блестящей и сатирированной
отделкой, стекло, изготовленное
вручную, сатирированное.





Floor lamp





D GOC PI 2313

Max 1x250W E27  halogen

CE IP20 

**Pendant lamp**

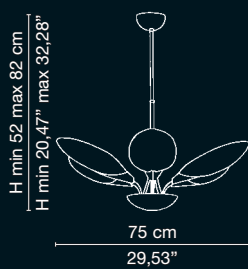
D GOC SO6 1613

Max 6x60W E14 CE IP20  



Ceiling lamp

D GOC PL5 1613

Max 5x60W E14

CE IP20

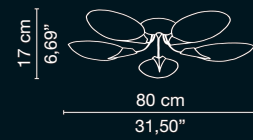

Ceiling lamp

D GOC PL3 1613

Max 3x60W E14

CE IP20

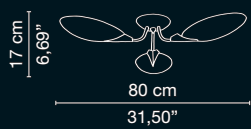

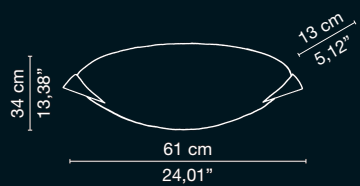



Ceiling lamp

D GOC PL1 1613

Max 2x60W E27 

CE IP40  



166



Ceiling lamp

D GOC PL2 1613

Max 2x60W E27 

CE IP40  





Wall lamp

D GOC AP1 1613

Max 1x100W E27 

CE IP20 



Wall lamp

D GOC AP2 1613

Max 1x60W E14 



CE IP20 



Table lamp

D GOC LU 1613

Max 1x60W E14 

CE IP20 

Struttura in metallo verniciato,
vetro in lastra extrachiaro satinato,
verniciato ambra o specchio.

Paint finish metal fixture, extra-clear
satin finish plate glass diffuser,
amber paint finish or mirror effect.

Monture en métal peint,
verre extra clair satiné,
finition ambre ou miroir.

168

Aufbau aus lackiertem Metall,
extra helles satiniertes Flachglas,
bernsteinfarben oder spiegelnd lackiert.

Estructura de metal pintado,
lámina de vidrio extraclara satinada,
pintada ámbar o espejo.

Конструкция из окрашенного
металла, стекло из высветленной
сатинированной пластины,
окрашенное в янтарный
цвет или зеркало.



Wall lamp

D DORE AP 08...

Max 1x150W R7s 114

halogen

CE IP20

D DORE AP A 08...

Max 2x18W G24d-2

02 13 27

CE IP20

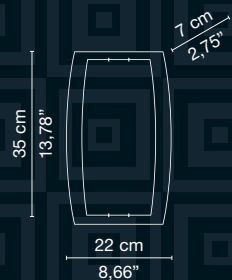
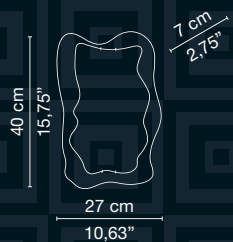

Wall lamp

D DOLA AP 08...

Max 1x150W R7s 114

halogen

CE IP20

D DOLA AP A 08...

Max 2x18W G24d-2

02 13 27

CE IP20







Wall lamp

D DODO AP 08...

Max 1x150W R7s 114 

halogen

CE IP20  

D DODO AP A 08...

Max 2x18W G24d-2 

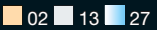

CE IP20   

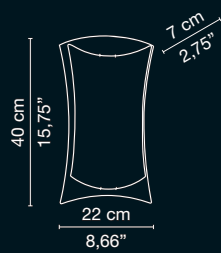





171

Wall lamp

D DOMI AP 08...

Max 1x150W R7s 114 
halogen

CE IP20  

D DOMI AP A 08...

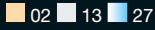
Max 2x18W G24d-2 
 02 ■ 13 ■ 27

CE IP20   

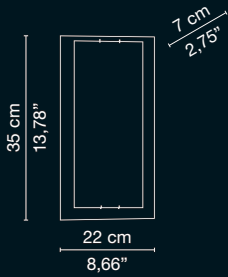

Aria

Struttura in cromo spazzolato,
particolari cromo lucido,
vetro soffiato.

Brushed finish chrome fixture
with polished chrome detailing.
Blown glass diffuser.

Monture en chrome brossé,
détails chrome brillant,
verre soufflé.

Aufbau aus gebürstetem Chrom,
glänzenden Chromdetails.
Geblasenes Glas.

Estructura de cromo cepillado,
detalles en cromo brillante.
Vidrio soplado.

Конструкция из сатинированного
хрома, элементы из блестящего
хрома. Выдувное стекло.



172



180 cm
70,87"

Floor lamp
D ARI PI 16...
Max 1x150W E27

24 cm
9,45"

■ 01 ■ 03

CE IP20

Pendant lamp
D ARI SOP 16...
Max 1x60W E14

■ 01 ■ 03

CE IP20

110 cm
43,21"

14 cm
5,51"

Pendant lamp
D ARI SOM 16...
Max 1x100W E27

■ 01 ■ 03

CE IP20

120 cm
47,24"

22 cm
8,66"



Pendant lamp

D ARI SO6 16...

Max 6x60W E14

■ 01 ■ 03

CE IP20

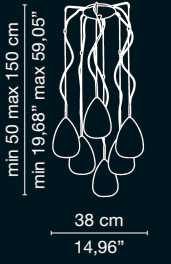

174



Pendant lamp

D ARI SO3 16...

Max 3x60W E14

■ 01 ■ 03

CE IP20



Pendant lamp

D ARI SO2 16...

Max 1x100W E27

Max 1x60W E14

■ 01 ■ 03

CE IP20





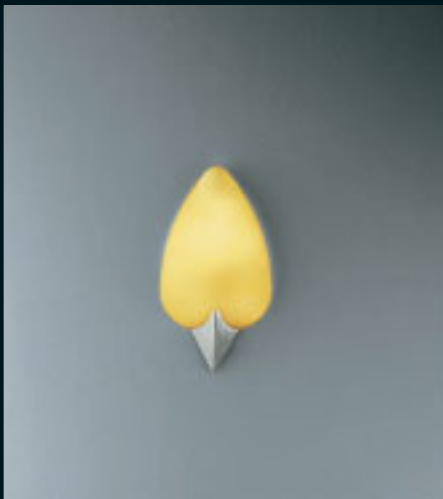



Wall lamp

D ARI AP2 16...

Max 1x40W E14 

■ 01 ■ 03

CE IP40 

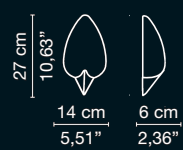

Wall lamp

D ARI AP3 16...

Max 1x100W E27 

■ 01 ■ 03

CE IP40 

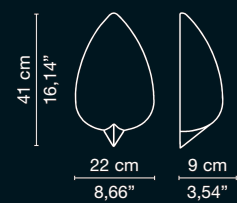



Desk lamp

D ARI LU 16...

Max 1x60W E14 

■ 01 ■ 03



CE IP20  





Table lamp

D ARI LT 16...

Max 1x100W E27 

■ 01 ■ 03

CE IP20  



Variant



Struttura in metallo cromato,
vetri soffiati.

Chrome plated metal fixture,
blown glass diffusers.

Monture en métal chromé,
verres soufflés.

Aufbau aus verchromtem Metall,
geblasenes Glas.

Estructura de metal cromado,
vidrio soplado.

Конструкция из хромированного
металла, выдувные стекла.

178



Pendant lamp

D VAR SO A...

Max 1x60W E14

01 02 12

CE IP20



Pendant lamp

D VAR SO B...

Max 1x60W E14

01 02 12

CE IP20



Pendant lamp

D VAR SO D...

Max 1x60W E14

01 02 12

CE IP20



Pendant lamp

D VAR SO C...

Max 1x60W E14

01 02 12

CE IP20







Pendant lamp

D VAR MO 16...

Max 12x60W E14 

■ 01 ■ 02 ■ 12

CE IP20  



CA 01 2 metri di cavo con portalampane
2 metres of cable with lamp socket
2 mètres de cable avec douille
2 Meter Kabel mit Lampenhalterung
2 metros de cable con portámparas
2 метра кабеля с ламподержателем

FC01 08 fermacavo da soffitto in cromo
chrome clamp to fasted cable to ceiling
serre-fil à plafond en chrome
Deckenkabelhalterung aus Chrom
sujetacable de techo color cromo
хромированный кабельный зажим для
установки на потолок

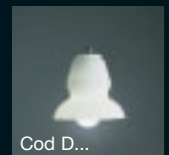

N.B. Specificare il numero di luci che si desidera (max 12, min 2)
Please specify the number of light wanted (max 12, min 2)
Préciser le numéro d'ampoules désirées (max 12, min 2)
Die Anzahl der gewünschten Leuchten ist anzugeben (max. 12, min. 2)
Especificar el número de luces que se desean (máx 12, mín 2)
Прим. Указать число требующихся лампочек (мак. 12, мин. 2)

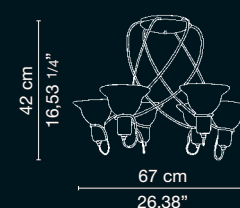
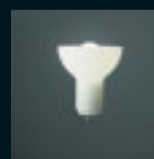
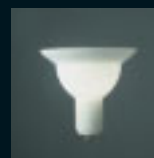

Ceiling lamp

D VAR PL6 16 ... (cod A/B)

Max 6x60W E14

■ 01 ■ 02 ■ 12

CE IP20

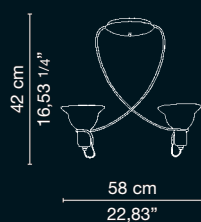

Ceiling lamp

D VAR PL2 16... (cod A/B)

Max 2x60W E14

■ 01 ■ 02 ■ 12

CE IP20

Flexo

Struttura in cromo spazzolato,
particolari cromo lucido.
Vetri soffiati.

Brushed finish chrome fixture with
polished chrome detailing.
Blown glass diffusers.

Monture en chrome brossé,
détails chrome brillant.
Verre soufflés.

Aufbau aus gebürstetem Chrom,
glänzenden Chromdetails.
Geblasenes Glas.

Estructura de cromo cepillado,
detalles en cromo brillante.
Vidrio soplado.

Конструкция из сатинированного
хрома, элементы из блестящего
хрома. Выдувные стекла.





Pendant lamp

D FLE SO2 16...

Max 1x60W E14

■ 01 ■ 02 ■ 12

CE IP20



Pendant lamp

D FLE SO1 16...

Max 1x60W E14





■ 01 ■ 02 ■ 12

CE IP20

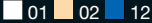

**Ceiling lamp**

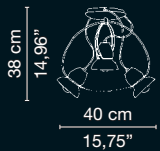
D FLE PL4 16...

Max 3x60W E14  01 02 12CE IP20  



Ceiling lamp

D FLE PL6 16...

Max 6x60W E14

■ 01 ■ 02 ■ 12

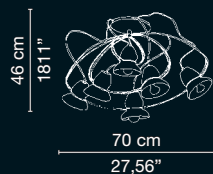
CE IP20





**Ceiling lamp**

D FLE PL3 16...

Max 3x60W E14 

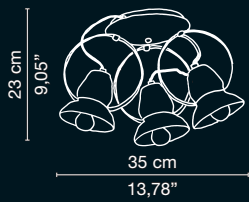
■ 01 ■ 02 ■ 12

CE IP20  



sp max 22 min 19 cm
sp max 8,66" min 7,48"

Wall lamp

D FLE AP 16...

Max 1x60W E14

■ 01 ■ 02 ■ 12

CE IP20

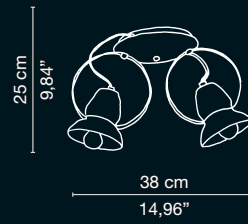

Ceiling lamp

D FLE PL2 16...

Max 2x60W E14

■ 01 ■ 02 ■ 12

CE IP20





 **Francolight**[®]
DESIGNING THE ITALIAN WAY

Collection two

Opera

Struttura in ottone, placcata argento 999,
e laccatura su versione colorata.

Brass fixture with a 999 silver plating
or coloured lacquer finish.

Monture en laiton, plaqué argent 999,
et lacqué sur la version colorée.

Aufbau aus Messing, 999 silberplattiert
und Lacküberzug bei farbiger Ausführung.

Estructura de latón, placada en plata 999,
y laqueada en las versiones coloreadas.

Латуневая конструкция,
плакированная серебром 999, и
лакировка на цветном варианте.







Pendant lamp

C OPERA SO28 31

16+8+4 Max 28x40W E14 

Montatura argento spazzolato,
particolari argento.

Brushed plated silver frame,
plated silver details.

 IP20  



Pendant lamp

C OPERA SO28 00

16+8+4 Max 28x40W E14 

Montatura nera, particolari argento.

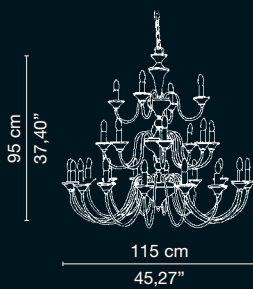

Black frame, plated silver details.

 IP20  

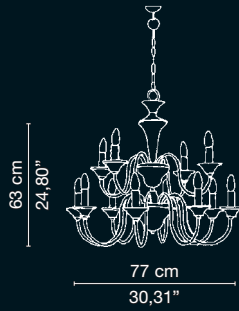





Pendant lamp
C OPERA SO12 31
 8+4 Max 12x40W E14 
 Montatura argento spazzolato,
 particolari argento.
 Brushed plated silver frame,
 plated silver details.



 IP20  

Pendant lamp
C OPERA SO12 00
 8+4 Max 12x40W E14 
 Montatura nera, particolari argento.
 Black frame, plated silver details.

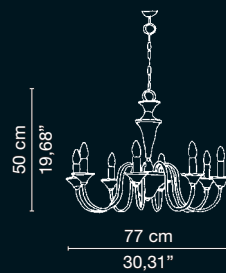
 IP20  



Pendant lamp
C OPERA SO8 31
 Max 8x40W E14 
 Montatura argento spazzolato,
 particolari argento.
 Brushed plated silver frame,
 plated silver details.

 IP20  



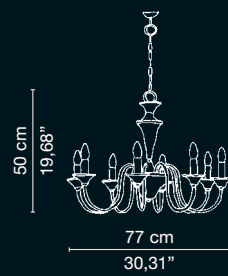

Pendant lamp

C OPERA SO8 00

Max 8x40W E14 

Montatura nera, particolari argenti.

Black frame, plated silver details.

CE IP20  



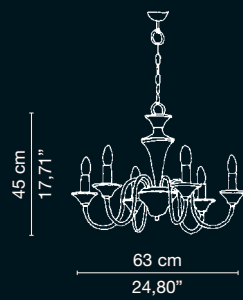



Pendant lamp

C OPERA S06 31

Max 6x60W E14 

Montatura argento spazzolato,
particolari argento.

Brushed plated silver frame,
plated silver details.



 IP20  

Pendant lamp

C OPERA S06 00

Max 6x60W E14 

Montatura nera, particolari argento.
Black frame, plated silver details.

 IP20  

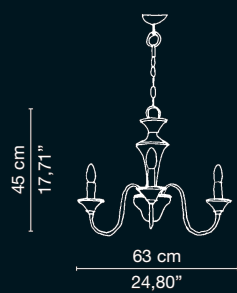

Pendant lamp

C OPERA S03 31

Max 3x60W E14

Montatura argento spazzolato,
particolari argento.

Brushed plated silver frame,
plated silver details.

CE IP20

Pendant lamp

C OPERA S03 00

Max 3x60W E14

Montatura nera, particolari argento.
Black frame, plated silver details.

CE IP20

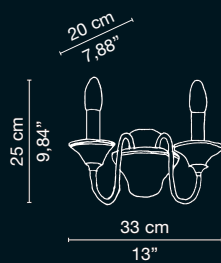

**Wall lamp**

C OPERA AP2 31

Max 2x60W E14

Montatura argento spazzolato,
particolari argento.Brushed plated silver frame,
plated silver details.

CE IP20

Wall lamp

C OPERA AP2 00

Max 2x60W E14

Montatura nera, particolari argento.

Black frame, plated silver details.

CE IP20





Table lamp

C OPERA LU 31

Max 1x60W E14

Montatura argento spazzolato,
particolari argento.

Brushed plated silver frame,
plated silver details.

IP20

Table lamp

C OPERA LU 00

Max 1x60W E14

Montatura nera, particolari argento.

Black frame, plated silver details.

IP20



Ducale

Struttura in ottone, placcata argento 999,
e laccatura su versione colorata.

Brass fixture with a 999 silver plating
or coloured lacquer finish.

200

Monture en laiton, plaqué argent 999,
et lacqué sur la version colorée.

Aufbau aus Messing, 999 silberplattiert
und Lacküberzug bei farbiger
Ausführung.

Estructura de latón, placada en plata
999, y laqueada en las versiones
coloreadas.

Латуневая конструкция,
плакированная серебром 999, и
лакировка на цветном варианте.









Pendant lamp

C DUCA SO12 11

8+4 Max 12x40W E14 

Montatura rossa, particolari argento.

Red frame, plated silver details.

CE IP20  



Pendant lamp

C DUCA SO12 31

8+4 Max 12x40W E14 

Montatura argento spazzolato,
particolari argento.

Brushed plated silver frame,
plated silver details.

CE IP20  

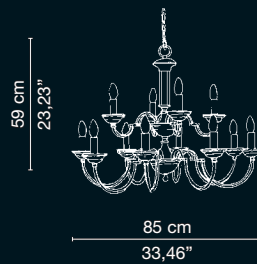



204

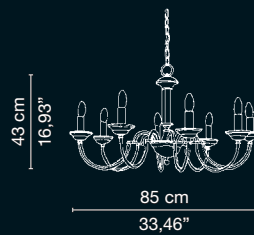

Pendant lamp

C DUCA S08 31

Max 8x40W E14

Montatura argento spazzolato,
particolari argento.

Brushed plated silver frame,
plated silver details.

CE IP20

Pendant lamp

C DUCA S08 11

Max 8x40W E14

Montatura rossa, particolari argento.
Red frame, plated silver details.

CE IP20





205

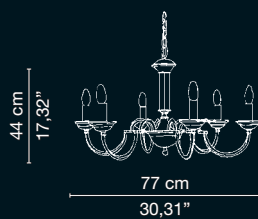



Pendant lamp

C DUCA S06 31

Max 6x60W E14 

Montatura argento spazzolato,
particolari argento.

Brushed plated silver frame,
plated silver details.



 IP20  

Pendant lamp

C DUCA S06 11

Max 6x60W E14 

Montatura rossa, particolari argento.
Red frame, plated silver details.

 IP20  



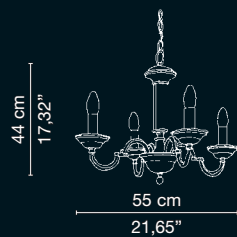

Pendant lamp

C DUCA S04 31

Max 4x60W E14

Montatura argento spazzolato,
particolari argento.

Brushed plated silver frame,
plated silver details.

CE IP20

Pendant lamp

C DUCA S04 11

Max 4x60W E14

Montatura rossa, particolari argento.

Red frame, plated silver details.

CE IP20





Wall lamp

C DUCA AP2 31

Max 2x60W E14 

Montatura argento spazzolato,
particolari argento.

Brushed plated silver frame,
plated silver details.

 IP20  



Wall lamp

C DUCA AP2 11

Max 2x60W E14 

Montatura rossa, particolari argento.

Red frame, plated silver details.

 IP20  

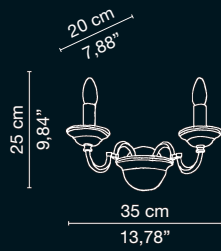



Table lamp

C DUCA LU 11

Max 1x60W E14

Montatura rossa, particolari argento.

Red frame, plated silver details.

CE IP20

Table lamp

C DUCA LU 31

Max 1x60W E14

Montatura argento spazzolato,
particolari argento.

Brushed plated silver frame,
plated silver details.

CE IP20



Reticello

210

Struttura in metallo verniciato,
vetro in piastra tirato a mano.

Paint finish metal fixture, handcrafted
drawn plate glass diffuser.

Monture en métal peint, finitions or
verre artistique cristal ou ambre.

Aufbau aus lackiertem Metall,
handgezogenes Flachglas.

Estructura de metal pintado,
lámina de vidrio estirada a mano.

Конструкция из крашеного
металла, стекло из пластины,
протянутое вручную.



Ceiling lamp

C RET PL1 01...

Max 3x60W E27

■ 02 ■ 04

CE IP40

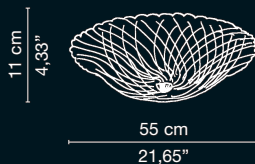

Ceiling lamp

C RET PL2 01...



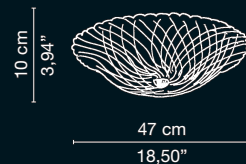

Max 3x60W E14

■ 02 ■ 04

CE IP40





Wall lamp
C RET AP 01...
Max 1x60W E14 
 02 04
CE IP20  

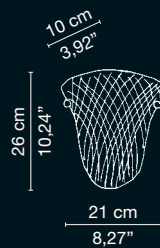

Spira

Struttura in metallo verniciato finiture oro, vetro in piastra tirato a mano.

Gold paint finish metal fixture, handcrafted drawn plate glass diffuser.

212

Monture en métal peint, finitions or verre artistique cristal ou ambre.

Aufbau aus lackiertem Metall, Goldfinishes, handgezogenes Flachglas.

Estructura de metal pintado con acabado en oro, lámina de vidrio estirada a mano.

Конструкция из крашеного металла с позолоченной отделкой, стекло из пластины, протянутое вручную.







Ceiling lamp

C SPI PL2 09...

Max 2x60W E14 

■ 02 ■ 04

CE IP20  

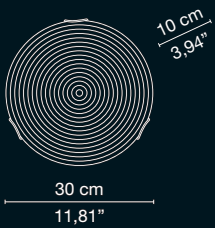



Ceiling lamp

C SPI PL3 09...

Max 2x60W E14 

■ 02 ■ 04

CE IP40  

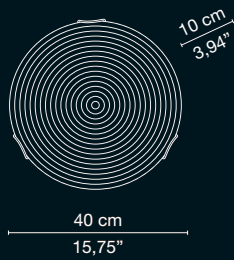



Ceiling lamp

C SPI PL1 09...

Max 3x60W E27 

■ 02 ■ 04

CE IP40  



Riga

Struttura in metallo verniciato finiture oro, vetro in piastra tirato a mano.

Gold paint finish metal fixture, handcrafted drawn plate glass diffuser.

214

Monture en métal peint, finitions or verre artistique cristal ou ambre.

Aufbau aus lackiertem Metall, Goldfinishes, handgezogenes Flachglas.

Estructura de metal pintado con acabado en oro, lámina de vidrio estirada a mano.

Конструкция из крашеного металла с позолоченной отделкой, стекло из пластины, протянутое вручную.



Ceiling lamp

C RIG PL1 09...

Max 2x60W E27

02 04

CE IP20

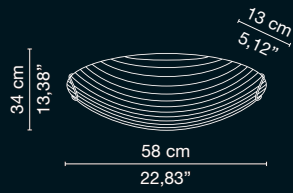

Ceiling lamp

C RIG PL2 09...

Max 2x60W E27

02 04

CE IP20

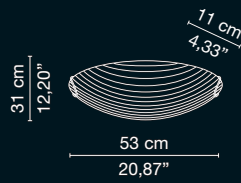

Wall lamp

C RIG AP1 09...

Max 1x100W E27

02 04

CE IP20

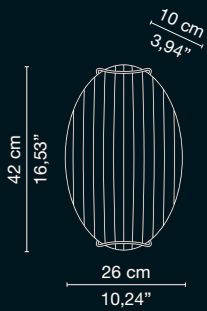

Wall lamp

C RIG AP3 09...

Max 1x60W E14

02 04

CE IP20

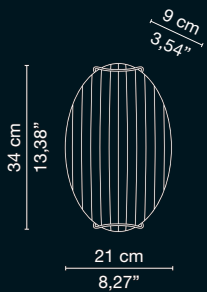

Wall lamp

C RIG AP2 09...

Max 1x60W E14

02 04

CE IP20

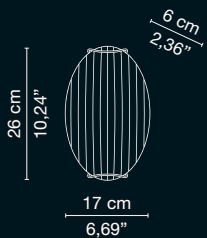

I seguenti articoli possono essere anche a soffitto.

The following articles could be also to ceiling.

Les articles suivants peuvent être placés à plafond.

Die folgenden Artikel können auch unter der Decke

angebracht werden.

Los siguientes artículos pueden ser también para techo.

Следующие изделия предлагаются также в варианте

для установки на потолок.



Camelia

Struttura in metallo verniciato
finitura oro, vetro in piastra
tirato a mano.

Paint finish metal fixture,
handcrafted drawn
plate glass diffuser.

Monture en métal peint,
finitions or verre artistique
cristal ou ambre.

Aufbau aus lackiertem Metall,
handgezogenes Flachglas.

Estructura de metal pintado,
lámina de vidrio estirada a mano.

Конструкция из крашеного
металла, стекло из пластины,
протянутое вручную.



216

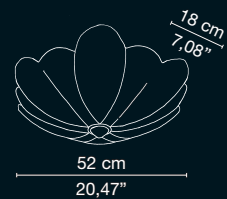

Ceiling lamp
C CAME PL3 09...
Max 3x60W E27
■ 02 ■ 04
CE IP20

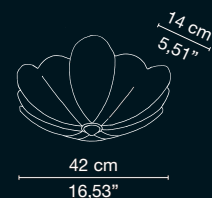



Ceiling lamp
C CAME PL2 09...
Max 2x60W E27
■ 02 ■ 04
CE IP20





Ceiling lamp

C CAME PL1 09...

Max 3x60W E27 

 02  04

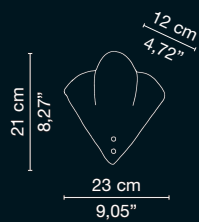
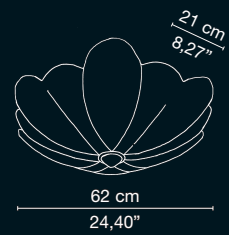

CE IP20  





Wall lamp

C CAME AP 09...

Max 1x60W E14 

 02  04

CE IP20  

Struttura in ottone
finiture oro o cromo, vetro
in piastra tirato a mano.

Gold paint or chrome finish
metal fixture, handcrafted
drawn plate glass diffuser.

Monture en laiton, finitions
or ou chrome, verre artistique
cristal ou ambre.

Aufbau aus Messing,
Gold oder Chrom,
handgezogenes Flachglas.

Estructura de latón
con acabado en oro o cromo,
lámina de vidrio estirada a mano.

Латуневая конструкция с
позолоченной или хромированной
отделкой, стекло из пластины,
протянутое вручную.



218

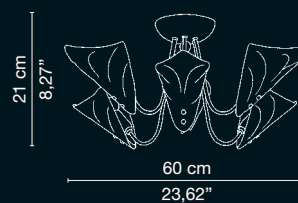



Ceiling lamp

C NID PL6 08...
cromo / chrome

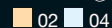
Max 6x60W E14 





CE IP20  

Ceiling lamp

C NID PL6 09...
oro / gold

Max 6x60W E14 









CE IP20  

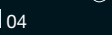

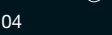
Ceiling lamp C NID PL8 09... oro / gold Max 8x60W E14  	Ceiling lamp C NID PL8 08... cromo / chrome Max 8x60W E14  
CE IP20  	CE IP20  



Wall lamp C NID AP 09... oro / gold Max 2x60W E14  	Wall lamp C NID AP 08... cromo / chrome Max 2x60W E14  
CE IP20  	CE IP20  

Sibilla

Vetro in piastra tirato a mano nei colori
cristallo o ambra, montatura dorata.

Hand drawn sheet glass diffusers,
colours available crystal or amber,
gold coloured fixture.

220

Verre artistique cristal transparent
ou ambre, monture dorée.

Glas aus handgezogenem Flachglas
in den Farben Kristall oder Bernstein,
vergoldeter Rahmen.

Lámina de vidrio estirada a mano de
color cristal o ámbar, montura dorada.

Стекло из пластины, протянутое
вручную, хрустального или янтарного
цвета, позолоченная оправа.



12 cm
4,72"





Ceiling lamp

C SIB PL2 09...

oro / gold

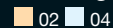
Max 2x60W E27 



CE IP40  



15 cm
5,90"

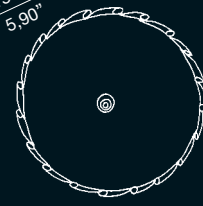



52 cm
20,47"

Ceiling lamp

C SIB PL1 09...

oro / gold

Max 3x60W E27 

 02  04

CE IP40  

Campanula

Vetro in piastra tirato a mano nei colori
cristallo o ambra. Montatura dorata.

Hand drawn sheet glass diffusers,
colours available crystal or amber.
Gold coloured fixture.

222

Verre artistique cristal transparent
ou ambre, monture dorée.

Glas aus handgezogenem Flachglas
in den Farben Kristall oder Bernstein.
Vergoldeter Rahmen.

Lámina de vidrio estirada a mano de
color cristal o ámbar. Montura dorada.

Стекло из пластины, протянутое
вручную, хрустального или янтарного
цвета. Позолоченная оправа.



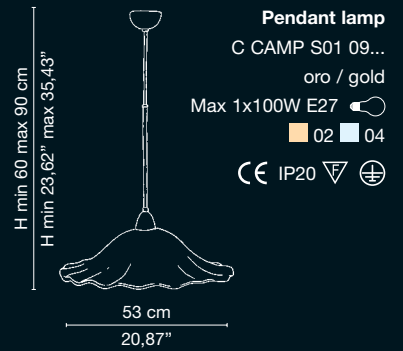
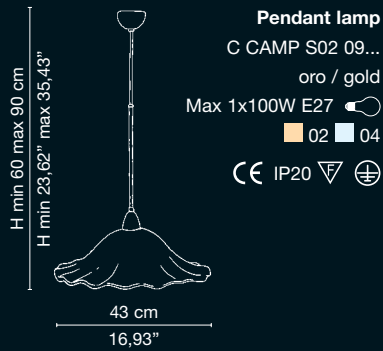

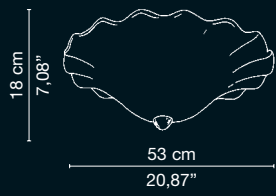

Ceiling lamp
 C CAMP PL1 09...
 oro / gold
 Max 3x60W E27
 ■ 02 ■ 04
 CE IP40

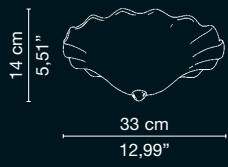

Ceiling lamp
 C CAMP PL2 09...
 oro / gold
 Max 2x60W E14
 ■ 02 ■ 04
 CE IP40

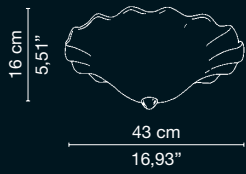

Ceiling lamp
 C CAMP PL3 09...
 oro / gold
 Max 3x60W E14
 ■ 02 ■ 04
 CE IP40



224



Wall lamp
 C CAMP AP 09...
 oro / gold
 Max 1x100W
 halogen short
 ■ 02 ■ 04
 CE IP20







225

Table lamp

C CAMP LU2 09...

oro / gold

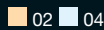
Max 1x60W E14 

 02  04

CE IP20 

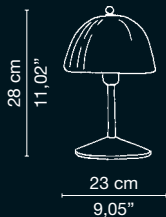

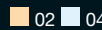



Table lamp

C CAMP LU 09...

oro / gold

Max 1x60W E14 

 02  04

CE IP20 

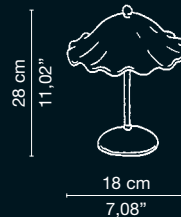

Shiny

Vetro in piastra tirato a mano nei colori ambra o cristallo con montatura dorata e, nella versione acidata, con montatura bianca.

Hand drawn sheet glass diffuser available in amber or crystal with a gold coloured fixture, the acid-etched glass diffuser is available with a white finish fixture.

Verre artistique dans les coloris ambre ou crystal transparent avec monture dorée, dans la version satiné, avec monture peint blanc.

Glas aus handgezogenem Flachglas in den Farben Bernstein oder Kristall mit vergoldetem Rahmen und in der satinierten Ausführung mit weißem Rahmen.

226



Lámina de vidrio estirada a mano de color ámbar o cristal con montura dorada y, en la versión acidada, con montura blanca.

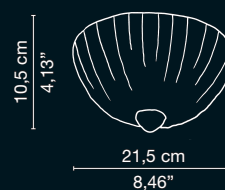

Стекло из пластины, протянутое вручную, хрустального или янтарного цвета, с позолоченной оправой, и в протравленном кислотой варианте с белой оправой.

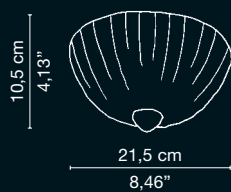



Ceiling lamp
C SHI PL2 09
cristallo con graniglia
crystal with grit finishing
Max 2x40W E14 
■ 02 ■ 04
CE IP20  



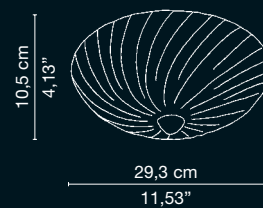

Ceiling lamp
 C SHI PL2 0113
 cristallo senza graniglia
 crystal without grit finishing
 Max 2x40W E14   13

CE IP40  



Ceiling lamp
 C SHI PL1 0904
 cristallo senza graniglia
 crystal without grit finishing
 Max 2x40W E14   04

CE IP40  

Petalo

Struttura in ottone dorato spazzolato con particolari in oro lucido, oppure in ottone brunito con particolari in oro lucido. Vetri in piastra tirati a mano.

Brushed gold finish brass fixture with polished gold coloured detailing or burnished brass with polished gold coloured detailing. Hand drawn sheet glass.

Monture en laiton dorée brossé avec détails en or brillant, ou laiton bruni avec détails en or brillant. Verres artistiques satinés.

Aufbau aus gebürstetem vergoldetem Messing mit Details in glänzendem Gold, oder in brüniertem Messing mit Details in glänzendem Gold. Glas aus handgezogenem Flachglas.

228

Estructura de latón dorado con detalles en oro brillante, o bien en latón pulido con detalles en oro brillante. Lámina de vidrio estirada a mano.

Конструкция из позолоченной полированной латуни с элементами из блестящего хрома или из отполированной до зеркального блеска латуни с блестящими позолоченными элементами. Стекла из пластины, протянутые вручную.

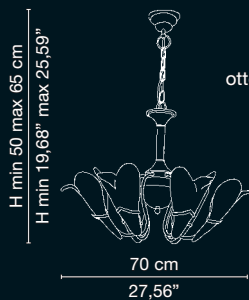

Pendant lamp

C PET S06 19...

ottone dorato / golden brass

Max 6x60W E14

13

CE IP20

Pendant lamp

C PET S06 26...

ottone brunito / antique brass

Max 6x60W E14

13

CE IP20







Pendant lamp

C PET S09 19...

ottone dorato / golden brass

Max 9x60W E14 

■ 13

CE IP20  

H min 50 max 75 cm
H min 19,68" max 29,53"

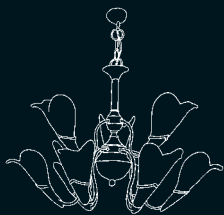

85 cm
34,46"

Pendant lamp

C PET S09 26...

ottone brunito / antique brass

Max 9x60W E14 

■ 13

CE IP20  

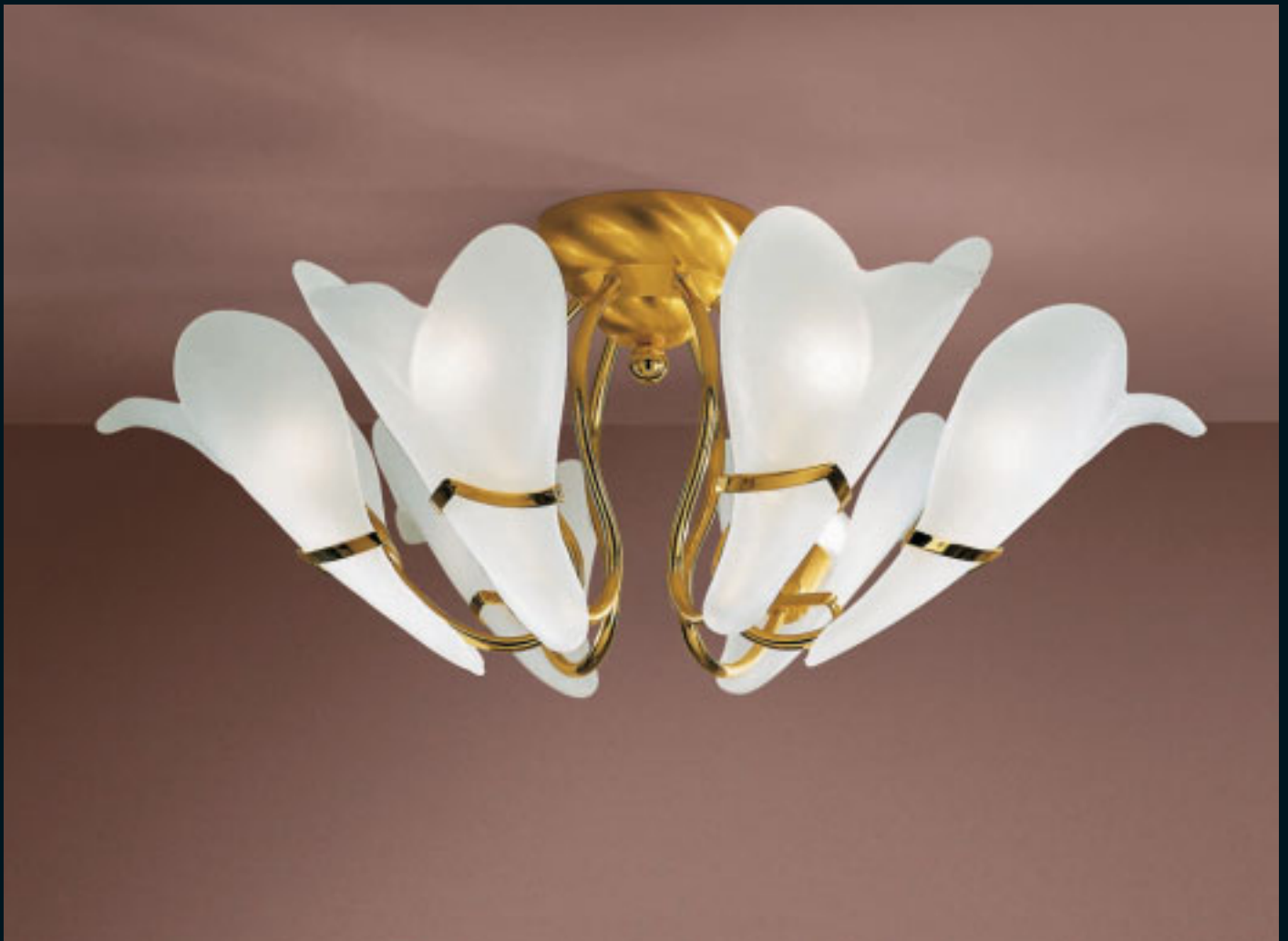



Ceiling lamp

C PET PL 19...

ottone dorato / golden brass

Max 6x60W E14 

■ 13

 IP20  





Ceiling lamp

C PET PL 26...

ottone brunito / antique brass

Max 6x60W E14 

■ 13

 IP20  



Wall lamp

C PET AP 19...

ottone dorato / golden brass

Max 1x60W E14

■ 13

CE IP20



Wall lamp

C PET AP 26...

ottone brunito / antique brass

Max 1x60W E14

■ 13

CE IP20



Table lamp

C PET LU 19...

ottone dorato / golden brass

Max 1x60W E14

■ 13

CE IP20



Table lamp

C PET LU 26...

ottone brunito / antique brass

Max 1x60W E14

■ 13

CE IP20

Astro



Struttura in ottone dorato
vetri in piastra tirati a mano.

Gold coloured brass fixture,
hand drawn sheet glass diffusers.

Monture en laiton doré,
verres artistiques cristal ou ambre.



Aufbau aus vergoldetem Messing,
Glas aus handgezogenem Flachglas.

Estructura de latón dorado,
lámina de vidrio estirada a mano.

Конструкция из позолоченной
латуни, стекла из пластины,
протянутые вручную.

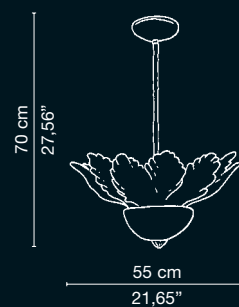
232

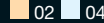

Pendant lamp
C ASTR S02 09...
Max 7x60W E14 
 02 04
CE IP20  







233

Pendant lamp

C ASTR S01 09...

Max 7x60W E14 



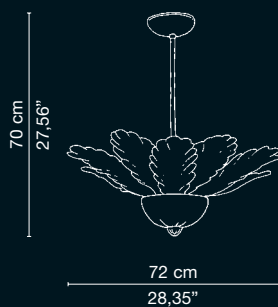

 02  04

CE IP20  

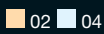

**Ceiling lamp**

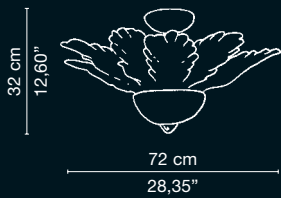

C ASTR PL1 09...



Max 7x60W E14  02 04CE IP20  

Ceiling lamp

C ASTR PL2 09...

Max 7x60W E14 

 02  04

CE IP20  

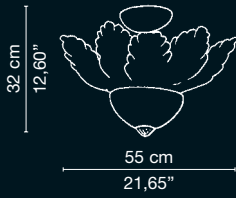

Armonia

Struttura in ottone dorato,
vetri in piastra tirati a mano.

Gold coloured brass fixture,
hand drawn sheet glass diffusers.

Monture en laiton doré,
verres artistiques cristal ou ambre.

Aufbau aus vergoldetem Messing,
Glas aus handgezogenem Flachglas.

Estructura de latón dorado,
lámina de vidrio estirada a mano.

Конструкция из позолоченной
латуни, стекла из пластины,
протянутые вручную.



236







237

Pendant lamp

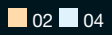
C ARMO S0 09...

Max 7x60W E14 



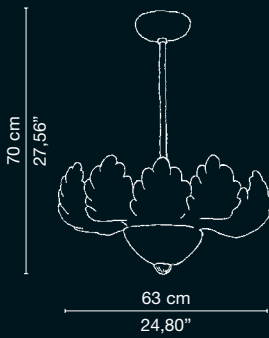

 02  04

CE IP20  

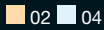

**Ceiling lamp**

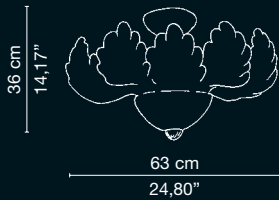
C ARMO PL 09...



Max 7x60W E14 CE IP20  





Wall lamp

C ARMO AP 09...

Max 1x100W E27 

 02  04

CE IP20  

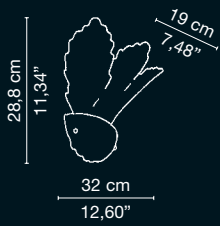



 **Francolight**[®]
DESIGNING THE ITALIAN WAY



Living division

Bouchon®

Realizzato in polietilene atossico,
riciclabile al 100% e stabilizzato UVA.

Manufactured from UVA
stabilized non-toxic
polyethylene 100% recyclable.

Réalisé en polyéthylène atoxique
100 % recyclable et stabilisé UVA.

Aus ungiftigem Polyethylen gefertigt, zu
100% recyclebar und UVA-beständig.

242

Realizado en polietileno atóxico,
100% reciclable y estabilizado UVA.

Изготовлено из нетоксичного
полиэтилена, перерабатываемого
на 100% и стабилизированного на
проникновение ультрафиолетового
излучения.



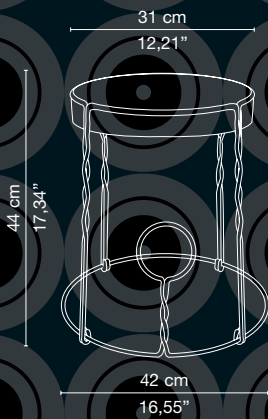
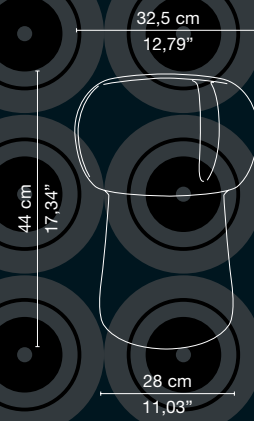



Mint_green

Apple_green



244



Lipstick_red

Ocean_blue





Cream_yellow



Banana_yellow



Sunset_orange



245





















amethyst_violet



Snow_white



Black_night

	LAMPADINE BULBS	ATTACCO BASE	WATT	FINITURA FINISHING	VOLTS
	sferica sphere	E14 E27	40-60	biancolatte opalizzata intern. internal soft white	230
	oliva regular A-shape	E14	40-60	biancolatte opalizzata intern. internal soft white	230
	goccia standard lamps	E27	75-100	biancolatte opalizzata intern. internal soft white	230
	spot R 80	E27	100	smerigliata con argentatura interna internal frosted silver coating	230
	sferica/G 120 sphere	E27	100-150	biancolatte opalizzata intern. internal soft white	230
	tubolare tubular	E27	150-250	smerigliata internamente internal frost finish	230
	lineare linear	R7s 78 mm R7s 114 mm	100-150 150-300	chiara light	230
	PAR 20	E27	50	riflettore dicroico dichroic reflector	230
	bassa tensione low voltage	GY 6,35	35-50	chiara light	12
	bassa tensione low voltage	GY 5,3	20-50	riflettore dicroico dichroic reflector	12
	PLC-E	E27	11-15 20-23	biancolatte opalizzata intern. internal soft white	230
	PL fluorescente compatta compact fluorescent	G23 s 1-2-3	9-10-13 18-24	biancolatte opalizzata intern. internal soft white	230
	DULUX L	2G11	24-36	biancolatte opalizzata intern. internal soft white	230
	PLC	G24q-2	18-26	biancolatte opalizzata intern. internal soft white	230
	Lampade fluorescenti circolari Circular fluorescent lamps	2Gx13	22-40-60	biancolatte opalizzata intern. internal soft white	230
	Lampade alogene a tensione di rete Mains voltage halogen lamps	G9	25-40 60-75	biancolatte opalizzata intern. internal soft white	230
	Lampade fluorescenti lineari Tubular fluorescent lamps	G5	24-39 54-80	biancolatte opalizzata intern. internal soft white	230
	Lampade siluro tubolari Tubular lamps	8,5-8	21	chiara light	230
	Lampade fluorescenti lineari Tubular fluorescent lamps	E27	23	biancolatte opalizzata intern. internal soft white	230



Apparecchio di classe II, munito di isolamento doppio o rinforzato.
Fixture on Class II, with double or reinforced insulation.



Apparecchio adatto ad essere installato su superfici normalmente infiammabili.
Fixture ready for mounting on normally inflammable surfaces



Risparmio di energia.
Energy saving.



Prodotto conforme alle normative europee.
Product conforms with European standards.



Classe I, messa a terra
Class I, earthed.



Grado di protezione
Protection degree

LETTURA DEI CODICI - HOW TO READ THE CODES

X XXXX XXX XX XX

Riferimento famiglia / Family reference

D = design / design

C = classico / classic

X XXX XXX XX XX

Nome abbreviato della serie / shortened series name

X XXX XXX XX XX

Tipologia del prodotto / Product typology

PI = Piantana / floor lamp

SO = Sospensione / suspended lamp

PL = Plafoniera / ceiling lamp

AP = Applique / wall lamp

LT = Lampada da tavolo / table lamp

LU = Lumetto / desk lamp

X XXX XXX XX XX

Proporzione / Proportion

Plafoniera / ceiling lamp

PL1 = Plafoniera grande o a 1 luce / large ceiling lamp or 1 light

PL2 = Plafoniera piccola o a 2 luci / small ceiling lamp or 2 lights

PL3 = Plafoniera media o a 3 luci o a 3 vetri
medium size ceiling lamp or with 3 lights or with 3 glass

PL4 = Plafoniera a 4 luci / ceiling lamp with 4 lights

PL6 = Plafoniera a 6 luci / ceiling lamp with 6 lights

PL7 = Plafoniera a 7 vetri / ceiling lamp with 7 glass

PL8 = Plafoniera a 8 luci / ceiling lamp with 8 lights

PL = Plafoniera Ø 700 mm / ceiling lamp Ø 700 mm

PLA = Plafoniera alta / high ceiling lamp

PLB = Plafoniera bassa / low ceiling lamp

Applique / wall lamp:

AP1 = Applique grande o a 1 luce / large wall lamp or with 1 light

AP2 = Applique piccolo o a 2 luci / small wall lamp or with 2 lights

AP3 = Applique medio o a 3 luci o a 3 vetri
medium size wall lamp or with 3 lights or with 3 glass

N.B.: La lettera "A" dopo i numeri di applique e plafoniere,
indica il basso consumo. Esempio: APA

N.B.: Letter "A" after wall brackets and ceiling lights
indicates low energy saving. Ex.: APA

Lampada a sospensione / suspended lamp:

SO1 = Sospensione grande o singola / large suspended lamp or single

SO2 = Sospensione piccola o a 2 luci
small suspended lamp or with 2 lights

SO3 = Sospensione a 3 luci / suspended with 3 lights

SO4 = Sospensione a 4 luci / suspended with 4 lights

SO6 = Sospensione a 6 luci / suspended with 6 lights

SO8 = Sospensione a 8 luci / suspended with 8 lights

SO9 = Sospensione a 9 luci / suspended with 9 lights

SO12 = Sospensione a 12 luci / suspended with 12 lights

SO28 = Sospensione a 28 luci / suspended with 28 lights

SOP = Sospensione piccola / suspended small

SOM = Sospensione media / suspended medium size

SOG = Sospensione grande / suspended large

SO1A = Sospensione Ø 500 mm verso l'alto
suspended Ø 500 mm upwards

SO1B = Sospensione Ø 500 mm verso il basso
suspended Ø 500 mm downwards

SO2A = Sospensione Ø 400 mm verso l'alto
suspended Ø 400 mm upwards

SO2B = Sospensione Ø 400 mm verso il basso
suspended Ø 400 mm downwards

SO1A = Sospensione Ø 500 mm verso l'alto
suspended Ø 500 mm upwards

SO1B = Sospensione Ø 500 mm verso il basso
suspended Ø 500 mm downwards

SO2A = Sospensione Ø 400 mm verso l'alto
suspended Ø 400 mm upwards

SO2B = Sospensione Ø 400 mm verso il basso
suspended Ø 400 mm downwards

SOA = Sospensione Ø 700 mm verso l'alto
suspended Ø 700 mm upwards

SOB = Sospensione Ø 700 mm verso il basso
suspended Ø 700 mm downwards

Lampada da tavolo / table lamp

LTA = Lampada da tavolo grande con stelo / large table lamp with rod

LTB = Lampada da tavolo piccola con stelo / small table lamp with rod

Lumetto / desk lamp

LUA = Lumetto senza stelo grande / large desk lamp without rod

LUB = Lumetto senza stelo piccola / small desk lamp without rod

X XXX XXX XXXX XX

Colore montatura / Frame colour

00 = nero / black

01 = bianco / white

08 = cromo / chrome

09 = oro / gold

11 = rosso / red

16 = nichel spazzolato / brushed nickel

19 = oro spazzolato / brushed gold

23 = grigio fumo / smoke gray

26 = brunito / antique brass

31 = argento / silver

X XXX XXX XX XX

Colore diffusore / Diffusor colour

● 00 = nero / black

○ 01 = bianco / white

● 02 = ambra / amber

● 03 = topazio / topaz

● 04 = cristallo / crystal

● 06 = giallo / yellow

● 10 = verde menta / mint green

● 11 = rosso / red

● 12 = blu / blue

● 13 = acidato / frosted

● 20 = multicolor / multicolor

22 = serigrafia ricamo / silkscreen printing "ricamo" (embroidery pattern)

● 23 = fucsia / fuchsia

● 24 = azzurro intenso / brilliant blue

● 26 = arancio / orange

● 27 = specchio / mirror

● 28 = verde mela / apple green

● 29 = azzurro cielo / sky blue

● 30 = viola / violet

● 31 = argento / silver

● 32 = wenghè / wengè

● 33 = fumè / smoked

Ferme restando le caratteristiche basilari del prodotto, FRANCOLIGHT S.r.l. si riserva di apportare eventuali modifiche in ogni momento al solo scopo di miglioramento. Le dimensioni degli apparecchi sono espresse in millimetri. *While preserving the basic characteristics of the product, FRANCOLIGHT S.r.l. reserves the right to make modifications at any time with the sole aim of improvement. Dimensions are expressed in millimeters.*

I colori riprodotti nel catalogo sono indicativi.

The colours reproduced in the catalogue are indicative.

CONDIZIONI GENERALI DI VENDITA

- 1) La merce viaggia a rischio e pericolo del committente, il quale all'occorrenza dovrà fare ricorso al trasportatore per raccomandata entro 48 ore dal ricevimento della stessa.
- 2) I dati riportati in questo catalogo sono indicativi e non costituiscono impegno da parte della Francolight, che si riserva di fare tutte le modifiche e migliorie alla struttura e al decorso in osservanza della normativa CE senza obbligo di preavviso.
- 3) Le colorazioni dei vetri sono suscettibili di piccole variazioni di tonalità.
- 4) La merce rimane di nostra proprietà finché non è avvenuto il pagamento.

GENERAL SALES CONDITIONS

- 1) Goods always travel at buyer's risk. Any claim for damage must be made by registered mail to the last carrier within 48 hours from receipt of the goods.
- 2) Informations and details as shown in this catalog are indicative and in no way binding on Francolight who reserves the right, at any time, and without notice to modify and improve their products in compliance with CE norms.
- 3) The colors of the glasses, are susceptible of light variations of tonality.
- 4) Francolight shall retain ownership of goods sold until payment in full of principal and incidental charges. Failure to pay any amount on due date shall result in the possession of these goods by Francolight.

ALLGEMEINE LIEFER-UND VERKAUFSBEDINGUNGEN

- 1) Der Versand der Ware ab Werk erfolgt auf Risiko des Käufers. Beschwerden müssen innerhalb von 48 Std. per Einschreibebrief an den Transporteur gerichtet werden.
- 2) Die in diesem Katalog aufgeführten Daten sind richtungsweisend und für Francolight nicht verpflichtend. Francolight behält sich vor, Änderungen und Verbesserungen unter Berücksichtigung der CE Vorschriften ohne Vorankündigung durchzuführen.
- 3) Geringfügige abweichungen in Farbe der Gläser sind möglich.
- 4) Die Ware bleibt bis zur vollständigen Bezahlung unser Eigentum.

CONDITIONS GENERALES DE VENTE

- 1) La marchandise voyage exclusivement aux risques et périls du destinataire qui devra, le cas échéant, exercer son recours contre le transporteur. Toutes réserves devront être formulées par lettre recommandée, adressée à ce transporteur, sous un délai maximum de 48 heures.
- 2) Les descriptions et indications mentionnées dans ce catalogue sont uniquement données à titre indicatif. Francolight se réserve le droit d'apporter à ses modèles, et ceci sans préavis, toutes modifications et améliorations qu'elle jugera nécessaires.
- 3) Le ton des coloris des verres est susceptible de légères variations.
- 4) Les marchandises restent la propriété de Francolight jusqu'au paiement intégral de celles-ci.

CONDICIONES GENERALES DE VENTA

- 1) La mercancía viaja a riesgo y ventura del cliente que en su caso deberá reclamar al transportista mediante carta certificada en las 48 horas sucesivas a la recepción de la misma.
- 2) Los datos indicados en este catálogo son ilustrativos y no constituyen obligación para Francolight, que se reserva la facultad de realizar mejoras en la estructura y en el procedimiento de fabricación en cumplimiento de las normativas CE sin estar obligada a avisar previamente.
- 3) Las coloraciones de los vidrios pueden presentar pequeñas variaciones de tonalidad.
- 4) La mercancía permanece propiedad del fabricante hasta que no se ha satisfecho su pago.

ОБЩИЕ УСЛОВИЯ ПРОДАЖ

- 1) Продукт транспортируется на страх и риск заказчика, который, в случае необходимости, должен заявить транспортной компании о возможном ущербе заказным письмом в течение 48 часов после получения товара.
- 2) Данные, указанные в этом каталоге, являются приблизительными и не налагают особых обязательств на компанию Francolight, которая оставляет за собой право без специальных предупреждений вносить любые изменения и улучшать структуру продукта, при полном соблюдении норм ЕС.
- 3) Расцветка стекла может меняться из-за незначительных изменений тональностей.
- 4) Товар остается нашей собственностью до полного осуществления платежа.

